

IS1A xx P18 / IS2A xx P18

Characteristics:

- 1- and 2-dimensional inclination sensors with measurement range: $\pm 10^\circ$ / $\pm 45^\circ$ / $\pm 60^\circ$ (depending on type)
- High resolution and accuracy
- 4...20 mA current interface
- Robust, simply mountable aluminium housing
- Suitable for industrial use :
 - Temperature range: -40°C to $+80^\circ\text{C}$
 - Degree of protection: IP65/67



The inclination sensor IS1A xx P18 serves, according to the model, for one-channel measurement of inclinations in the ranges $\pm 10^\circ$, $\pm 45^\circ$ or $\pm 60^\circ$. The inclination sensor IS2A xx P18 includes two channels. The full-scale readings are calibrated factory-made at 25°C .

The compact and robust design makes the sensor a suitable angle measurement device in rough surroundings for different applications in industry and automotive technology.

Applications:

- Industry automation
- Agricultural and forestry machines
- Utility vehicles
- Crane and hoisting technology

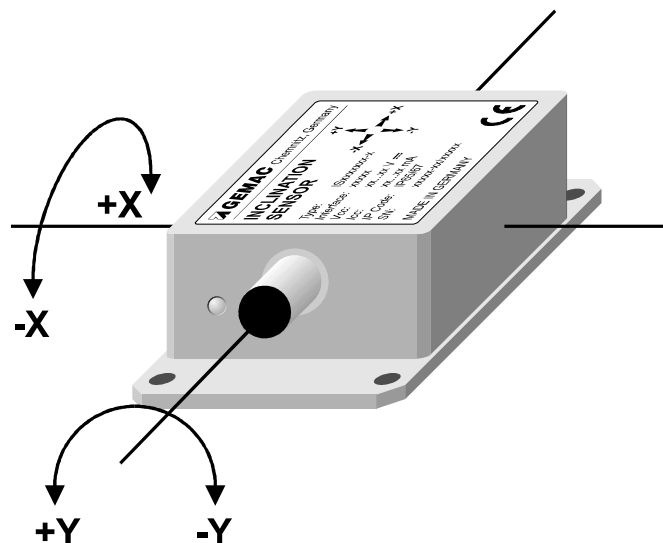

Technical Data:

General Parameters	
Measurement axes	1 axis (IS1A xx P18), 2 axes (IS2A xx P18)
Measurement ranges	$\pm 10^\circ / \pm 45^\circ / \pm 60^\circ$
Resolution (at zero point)	$0.01^\circ / 0.05^\circ / 0.05^\circ$
Calibration accuracy (at 25° C)	$\pm 0.3^\circ / \pm 0.5^\circ / \pm 0.5^\circ$ (zero point and accumulated values)
Nonlinearity (sine)	Max. $\pm 0.2^\circ / \pm 0.3^\circ / \pm 0.4^\circ$
Temperature coefficient (zero point)	Max. $\pm 0.009^\circ/\text{K} / \pm 0.009^\circ/\text{K} / \pm 0.009^\circ/\text{K}$
Critical frequency	typ. 18 Hz
Operating temperature	-40 °C to +80 °C
Characteristics	
Interface	current loop 4...20 mA
Electrical Parameters	
Supply voltage	15 V DC to 30 V DC
Current consumption	< 25 mA
Mechanical Parameters	
Connector	sensor connector 5-pole (M12)
Degree of protection	IP65/67
Shock survival	Max. 3,500 g
Dimensions	58 mm x 90 mm x 31 mm
Mass	about 200 g

Dimensioned Drawing:

The four bores for fixing the sensors are situated in the basic plate of the inclination sensor. The additional M5 press-in bolt is used as mass-connector.

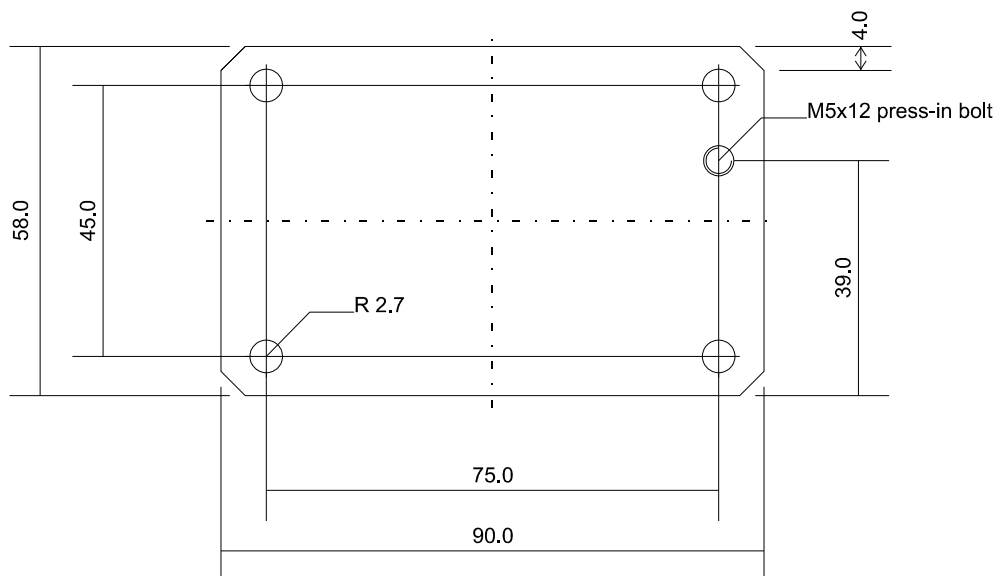

Dimensions in mm

Plug Connector Allocation:

Pin	Allocation
1	Supply voltage
2	Sensor signal Y-axis
3	GND
4	Sensor signal X-axis
5	Reference potential for sensor signal

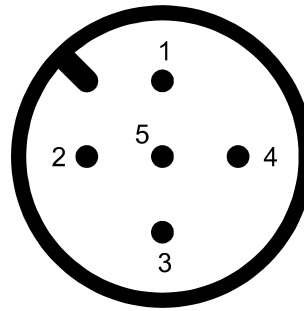

(View from the outside)

Ordering Information:

Type	Description/Distinction	Article Number
IS1A 10 P18	1-dimensional, $\pm 10^\circ$, 4...20 mA	PR-24000-00
IS1A 45 P18	1-dimensional, $\pm 45^\circ$, 4...20 mA	PR-24001-00
IS1A 60 P18	1-dimensional, $\pm 60^\circ$, 4...20 mA	PR-24002-00
IS2A 10 P18	2-dimensional, $\pm 10^\circ$, 4...20 mA	PR-24200-00
IS2A 45 P18	2-dimensional, $\pm 45^\circ$, 4...20 mA	PR-24201-00
IS2A 60 P18	2-dimensional, $\pm 60^\circ$, 4...20 mA	PR-24202-00