

INCLINOMETER RS232 - CURRENT



Main Features

- Two axis digital inclinometer
- Angle measurement range of $\pm 5^\circ$, $\pm 15^\circ$ and $\pm 30^\circ$, Resolution up to 0.001°
- Active linearization and temperature compensation
- Interface: RS232, Code:ASCII
Current 4...20mA
- Housing: 70 mm Ø

Applications

- Structural engineering
- Levelling techniques
- Measuring techniques
- Inclinations
- Mechanical Structure

Programmable Parameters

- Transmission mode: Polled Mode, Cyclic Mode
- Cycle Time
- Setting of zero point
- Baud-rate 2.4 – 56 KBAud

Electrical Features

- Linear and temperature compensated characteristic line
- Microprocessor controlled
- Polarity inversion protection
- Over-voltage-peak protection
- Highly integrated circuit in SMD-technology

INCLINOMETER RS232 - CURRENT

Technical Data

Electrical Data

Model	AGS 5	AGS 15	AGS 30
Measuring range	+/- 5°	+/- 15°	+/- 30°
Resolution digital	0.001°	0.001°	0.01°
Resolution analog	0,001°	0,005°	0,01°
Accuracy	0,01°	0,01°	0,02°
Inclination angle in x and y (1)	+/-15°	+/-40°	+/-60°
Damping period 5° > 0°	typical 1s 10%, 2s 1%, 3s 0.1%		
Digital interface	RS232 format ASCII		
Baud rate	Max. 56 k		
Analog interface	4...20mA , 0°= 12mA ; Load 300 Ohm		
Supply voltage (2)	10 - 30 V DC (absolute limits)		
Current consumption	typical 50 mA		
EMC	Emitted interference: EN 61000-6-3		
	Noise immunity: EN 61000-6-2		
Electrical lifetime	> 10 ⁵ h		

(1) Supply voltage is applied.

(2) Inclinometers should be connected only to subsequent electronics whose power supplies comply with EN 50178 (protective low voltage)

Mechanical Data

Housing	Aluminum
Lifetime	> 10 ⁵ h
Shock	A=30g; t= 11ms, halfsine ; EN 60068-2-27
Vibration	10 to 150 Hz, 2,5 mm amplitude, 5g const. Acceleration, 1 Octave /Minute ; EN 60068-2-6
Weight (standard version)	350 g

Environmental Conditions

Operating temperature	-40 °C.....+85 °C
Storage temperature	-40 °C.....+85 °C
Humidity	98 % (without liquid state)
Protection class	IP 67 (connected); EN 60529

INCLINOMETER RS232 - CURRENT

Installation

Electrical Connection

The inclinometer is connected via 8 pin round connector or a Cable

Connector Assignment

Pin	Description	P8F-Cable	CRW-Cable
1	+UB Supply voltage	white	white
2	RxD	brown	brown
3	TxD	green	green
4	Ground (Supply)	yellow	yellow
5	X-Output	grey	grey
6	S-Ground	pink	pink
7	Y-Output	blue	red
8		red	

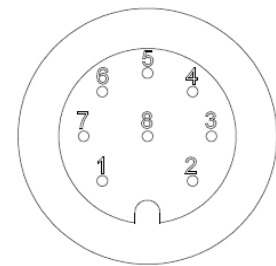

Front view of housing
Connector inclinometer

output signal (X,Y) analog current 4...20mA (+x,y°... -x,y°)

Instructions to mechanically install



Do not connect the inclinometer under power!



Do not stand on the inclinometer!



Avoid mechanical load!

INCLINOMETER RS232 - CURRENT

Reference Level

The Inclinator has a mounting reference angel (black line)for an optimal mounting of the inclinometer, which is parallel to the x-axis. This reference angle must be placed exactly parallel to the object to be measured to prevent or minimize any mechanical offset/cross sensitivity.

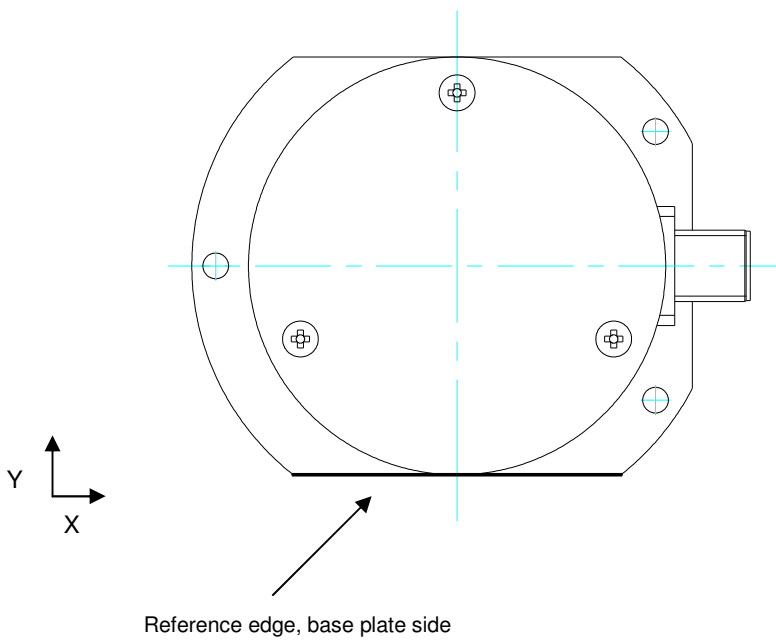

Reference angle of the inclinometer, top view

INCLINOMETER RS232 - CURRENT

Mounting and Installation Instruction

The inclinometer is designed for a horizontal mounting, i.e. the base plate of the inclinometer with the three mounting holes needs to be placed on the horizontal plane of the object to be measured. It can be mounted with M4 screw as a maximum.

The mounting surface must be plane and free of dust and grease. We recommend cheese head screws with metrical thread M4 for the mounting. Maximum fastening torque for the mounting screws is 10 Nm.

Installation

Prior to installation, please check for all connection and mounting instructions to be complied with. Please also observe the general rules and regulations on low voltage technical devices.

Avoid shock and vibration during measurement, as these could corrupt the measurement results. Inclination sensors that base on a fluidic measurement principle are optimal for static measurements and suitable to only a limited extent of dynamic measurement.

Measurement

The measurement of the tilt angle of the single measurement axis is carried out over the respective longitudinal and lateral axis of the inclination sensor. Reference is always the horizontal plane.

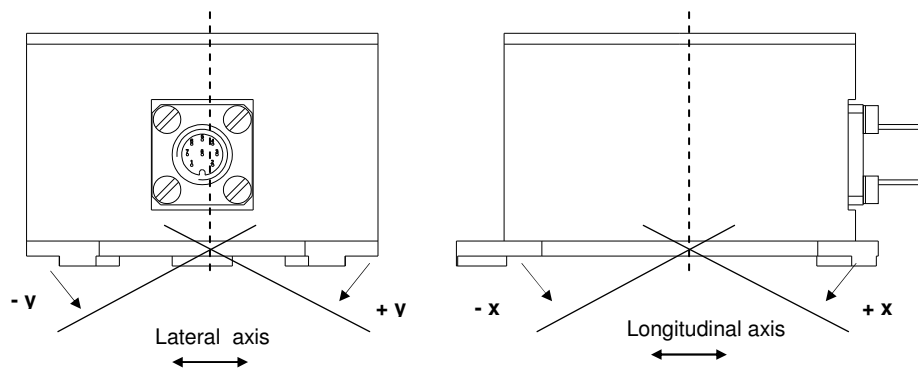

View of male socket

Side view

INCLINOMETER RS232 - CURRENT

Models/Ordering Description

Description	Type Key
Absolute inclinometer	AGS . . . -2-S . 1- H0- . . . -
Measuring range	005 015 030
Number of axis	
RS232	
without interface	O
Voltage interface	V
Current interface	C
PWM	P
Switch	S
Version	
Mechanical construction	Horizontal
Dynamic	2 mPas
Connection	plug, 8 pins P8M 1 m cable exit CRW
Option	-

Accessories and Documentation

Description		Type
Connector, counterpart	8 pins	P8F
Cable	STK 8, 2m, Plug P8F	P8F-STK8.2
	STK 8, 5m, Plug P8F	P8F-STK8.5

INCLINOMETER RS232 - CURRENT

Serial Interface RS 232

Communication with the sensor is done through a standardized RS-232 interface. Data transmission is effected in duplex mode. The baud rate is fixed by 9600 baud. After Power On the sensor is sending continuous the angle values in degrees (°). In the setup level several settings can be permanently modified. If the continuous mode was permanently changed to the polling mode, the sensor will send after "Power On" a start information with actual parameters. On error no angle values are sending and after "Power On" a error message was add to the start information.

Programming Instructions

Basic Settings

After Power On, the sensor is in the user level. In factory setting (==Free running mode) every 100ms the current angle values are continuously supplied with a baud rate of 9600 bd. In the Setup-level several settings can be changed permanent like query or free running mode, output rate, baud rate and angle offset. If query mode instead of free running mode is ser, the sensor will send start information with the current settings after Power On. In case of errors no angle values will be provided and after Power On an error message will be added to the start information.

Interface parameter:

9600 Baud , 8 data bits, parity even, 1 stop bit,

The baud rate can be adjusted to different values in the Setup-level.

Structure:

Baud rate: 9600 Baud (factory setting, changes in Setup-Mode possible)

Format: ASCII, 8 data bits, 1 stop bit, parity even

Length: 22 byte

Display: <D0 ... D21>

D0 ... D10 = "X=±xx.xxx", <CR>, <LF>
with D2 = sign (+ or -)
with D5 = point

D11 ... D21 = "Y=±xx.xxx", <CR>, <LF>
with D13 = sign (+ or -)
with D16 = point

Display example:

```
...  
X=+00.430  
Y=-00.084  
...
```

INCLINOMETER RS232 - CURRENT

Commands in user level

Table 1: instructions at user level

instruction	to the sensor	response sensor	explanation
activate temporary polling mode (1) (2)	"f"	"f"	the continuous sending of angle values are stopped, instructions can send to the sensor
activate temporary continuous mode (1) (2)	"F"	„X=±xx.xxx“, CR, LF, "Y=±xx.xxx", CR, LF, "X= . . .	X angle in ° Y angle in ° with „±“ = „+“ or „-“, one string contains x and y value
read angle values at one-time (3)	"R"	"X=±xx.xxx", CR, LF, "Y=±xx.xxx", CR, LF,	X angle in ° Y angle in ° with „±“ = „+“ or „-“
switch to the setup level (3) (4)	"prog"	"P"	Sensor is at setup level
show active level (3)	"**"	"Ux" or "Sx"	„U“ means Sensor is at User level „S“ means Setup-level is active, with „x“ Output-Mode of Sensors „U“ / „I“ / „P“ / „S“

- (1) In free running mode measurement data is continuously displayed. In query mode measurement and display is only once on command.
- (2) After reset or new Power On after an interruption of power supply, the sensor will be in user-level again with the original setup or with the setup changed in the setup level.
- (3) Only possible in query mode (=free running mode deactivated).
- (4) The Input of „prog“ must take place within 20 sec.

INCLINOMETER RS232 - CURRENT

Setup Level

The Setup level is active until "Power On" or Reset. All settings taken in the setup level are stored in the EEPROM and permanent available also after Power down.

Table 2: instructions at setup level

instruction	to the sensor	response sensor	explanation
activate permanent polling mode (1)	"f"	"f"	the continuous sending of angle values are permanent stopped, instructions can send to the sensor
activate permanent continuous mode (1)	"F"	"X=±xx.xxx", CR, LF, "Y=±xx.xxx", CR, LF, "X= . . ."	continuous sending of X angle in ° Y angle in ° with „±“ = „+“ or „-“
set rate of data transmission for continuous mode (2) (3) (4)	"O" <Code transmission rate>	"O" <Code transmission rate>	Echo, Code transmission rate or „E“ for Error, if the code is outside defined values
read angle values at one-time (2)	"R"		same as at user level
read version (2)	"V"	"AGSxxx-2-Sx", CR, LF "SN:xxx-xxx", CR, LF "HV:xx.x", CR, LF "SV:xx.x", CR, LF	type of Sensor serial number HW Version internal sensor SW Version
offset adjust of the specified axis (2) (3)	"n" "x" or "y"	"n" "OffsetX=±xx.xxx" or "OffsetY=±xx.xxx"	the actual angle of specified axis is set to zero, ±xx.xxx is the internal offset in degree
reset offset adjust (2) (3)	"N"	"N"	the offset adjust was reset to the original value
Set Baud rate (2) (3) (6)	"B" <Code Baud rate>	"B" <Code Baud rate>	Echo, Code Baud rate or „E“ for Error, if the code is outside defined values
Filter deaktivieren	„M0“	„M0“	all filters are deactivated
Moving Average Filter (10)	„M1“, „mm“	„M1mm“	Filter: Moving Average Filter is activated
Exponential Filter (10)	„M2“, „tt“	„M2tt“	Filter: Exponential Filter is activated

INCLINOMETER RS232 - CURRENT

Set switch angle for one axis (2) (3) (7) (8)	“Sx” <switch angle> or “Sy” <switch angle>	“Sx” or “Sy” <switch angle>	Echo, switch angle or „E“ for Error, if the angle is outside admissible range
Set hysteresis for switching point in both axis (2) (3) (7) (9)	“Sh” <hysterese>	“Sh” <hysterese>	Echo, hysterese or „E“ for Error, if the angle is outside admissible range
show active level (2)	“*“		same as at user level
Reset (2)	“q“	“q“	Software-Reset will be executed

- (1) in the continuous mode the sensor is sending continuous angle values, in the polling mode the sensor is sending one answer after an instruction
- (2) only possible at polling mode.
- (3) for activating a reset or power fail restart is necessary
- (4) for Code transmission rate see
- (5) Table 3 <Code transmission rate >
- (6) for Code baud rate see Table 5 <Code Baud rate>
Attention! A reset of the baud rate to a default value is not possible. If the user forgets the adjusted baud rate, the new value must be detected by testing.
- (7) this instruction is only effectual at sensors with switch output,
- (8) <switch angle>: three digits from “001” until “300” for the angle in tenths of a degree, max working range of the sensor. Default value is 025 == 2,5°
- (9) <hysterese>: two digits from “01” until “99” for the stitching hysterese in tenths of a degree, max working range of the sensor , Default value is 01 == 0,1°
- (10) Formulas for Filter :
 - Moving Average Filter „M1“, „mm“
(possible values mm = 02 to 40, with mm = 00 is moving average filter deactivated):
Output value = Average over last mm values.
 - Exponential Filter „M2“, „tt“ (first order low pass filter,
possible values tt = 02 to 40, with tt = 00 is exponential filter deactivated):
Output value = (old output value * (tt-1) / tt) + (value / tt)

INCLINOMETER RS232 - CURRENT

Table 4 <Code transmission rate >

<Code transmission rate >	strings per second, 1 string contains x and y-value
"0"	reserved
"1"	25 Strings/s (11)
"2"	10 Strings/s, Default value (12)
"3"	5 Strings/s
"4"	2 Strings/s
"5"	1 Strings/s
"6"	0,2 Strings/s
"7"	0,1 Strings/s
"8", "9"	not defined

(11)only allowed with baud rate of at least 9600 Bd

(12)only allowed with baud rate of at least 4800 Bd

Table 5 <Code Baud rate>

<Code Baud rate>	baud rate
"0"	2400 Baud
"1"	4800 Baud
"2"	9600 Baud, Default value
"3"	19200 Baud
"4"	38400 Baud
"5"	57600 Baud
"6", "7", "8", "9"	not defined

Example for setting the output rate

In the following example the output rate is set to 1 string per second

instruction	to the sensor	response sensor	explanation
		„X=±xx.xxx“, CR, LF, "Y=±xx.xxx", CR, LF, "X= . . .	continuous sending of angles
activate temporary polling mode	"f"	"f"	the continuous sending of angle values are stopped, instructions can send to the sensor
switch to the setup level	"prog"	"P"	Sensor is at setup level
set rate of data transmission for continuous mode	"05"	"05"	Code transmission rate is set to 1Strings/s

INCLINOMETER RS232 - CURRENT

Reset	“q”	“q”	Software-Reset will be executed, the new settings are guilty
		„X=±xx.xxx“, CR, LF, ”Y=±xx.xxx“, CR, LF, ”X= . . .	continuous sending of angles at 1 Strings/s

We do not assume responsibility for technical inaccuracies or omissions. Specifications are subject to change without notice.