

POSITAL

FRABA

DATASHEET

ABSOLUTE MAGNETIC ROTARY ENCODER CANOPEN



High-resolution absolute encoder based on magnetical technology. Singleturn encoding based on 360° Hall technology. Multiturn encoding based on magnetic pulse counter. No batteries used.

Main Features

- Compact industrial model
- Interface: CANopen (DS406)
CANopen Lift (DSP417)
- Housing: 36.5 mm Ø
- Solid Shaft: 6 or 10 mm Ø
- Blind hollow shaft: 6 mm Ø
- EMC: EN 61000-6-2, EN 61000-6-4
- Max. revolution not limited (typical 15 bit)
- Velocity and Acceleration Output
- LSS services

Mechanical Structure

- Aluminum flange
- Nickel-plated steel housing
- Stainless steel shaft
- Precision ball bearings

Programmable Parameters

- Baud rate and CAN-Identifier
- Resolution per revolution
- Total resolution
- Direction of rotation (complement)
- Preset value
- Two limit switches
- Transmission mode: Polled mode, cyclic mode, sync mode

Electrical Features

- Polarity inversion protection
- Over-voltage-peak protection
- Galvanic Isolation

AMERICA
FRABA Inc.
1800 East State Street, Suite 148
Hamilton, NJ 08609, USA
T +1 609 750-8705, F +1 (609) 750-8703
www.posita.com, info@posita.com

EUROPE
POSITAL GmbH
Carlswerkstrasse 13c
D-51063 Köln, GERMANY
T +49 221-96213-0, F +49 221-96213-20
www.posita.eu, info@posita.eu

ASIA
FRABA Pte. Ltd.
8 Temasek Boulevard
Singapore 038988, SINGAPORE
T +65 6829 2348, F +65 6829 2121
www.posita.sg, info@posita.sg

DATASHEET

ABSOLUTE MAGNETIC ROTARY ENCODER CANOPEN

Technical data

Electrical data

Interface	Transceiver according ISO 11898, galvanically isolated by opto-couplers
Transmission rate	max. 1 MBaud
Device addressing	Adjustable by SDO telegrams or Layer Setting Services
Supply voltage	10-30 V DC (absolute maximum ratings) *
Current consumption	max. 100 mA with 10 V DC, max. 50 mA with 24 V DC
Power consumption	max 1,2 Watts
Electrical lifetime	> 10 ⁵ h
EMC	Emitted interference: EN 61000-6-4 Noise immunity: EN 61000-6-2

* Supply voltage according to EN 50 178 (safety extra-low voltage)

Sensor data

Singleturn technology	magnetic 2 axis Hall sensor
Singleturn resolution	up to 4096 steps / revolution (12 Bit)
Singleturn accuracy	± 0.35°
Internal cycle time Singleturn	< 1 ms
Multiturn technology	self supplied magnetic pulse counter (Wiegand Sensor)
Multiturn resolution	Can measure up to 200 Billion revolutions

Environmental Conditions

Operating temperature sensor (*)	- 30 ... + 85 °C (-22 ...+185 °F)
Storage temperature (*)	- 30 ... + 85 °C (-22 ...+185 °F)
Humidity	98 % (without liquid state)
Protection Class (EN 60529)	Casing side: IP 54 (moulded : MCD-...-CAW) Casing side: IP 64 (other types : MCD-...-PAM and MCD-...-GAW) Shaft side: IP 64

(*) Please also refer temperature range of cable

POSITAL

FRABA

DATASHEET

ABSOLUTE MAGNETIC ROTARY ENCODER CANOPEN

Mechanical data

Housing	nickel-plated steel housing
Flange	Aluminum
Shaft	stainless steel
Lifetime	Dependent on shaft version and shaft loading – refer to table
Max. shaft loading	axial 40 N, radial 110 N
Inertia of rotor	$\leq 30 \text{ gcm}^2$ (0.11 oz-in ²)
Friction torque at + 25°C	$\leq 3 \text{ Ncm}$ (2.8 oz-in)
RPM (continuous operation)	max. 12.000 RPM
Shock (EN 60068-2-27)	$\leq 100 \text{ g}$ (half sine, 6 ms)
Permanent shock (EN 60028-2-29)	$\leq 10 \text{ g}$ (half sine, 16 ms)
Vibration (EN 60068-2-6)	$\leq 10 \text{ g}$ (10 Hz ... 1,000 Hz)
Weight (standard version)	$\approx 150 \text{ g}$ (0.33 lbs) including cable

Minimum (mechanical) lifetime

Flange	Lifetime in 10 ⁸ revolutions with (F _a /F _r)		
S6 Synchro flange (MCD-...-S060-...)	224 (20N/20N)	28 (20N/40N)	3 (20N/80N)
C100 flange (MCD-...-C100-...)	247 (40N/60N)	104 (40N/80N)	40 (40N/110N)

Cable (*)

Operating temperature cable	flexing -5°C to +70°C (+23 ... +158 °F) static -30°C to +70°C (-22 ... +158 °F)
Minimum bend radius	flexing 10x cable diameter static 5x cable diameter
Cable	approx 6 mm (~0.236 in) Ø / type : LIYCY 4x2x0.14

(*) Valid for types: MCD-...-CAW and MCD-...-GAW

ABSOLUTE MAGNETIC ROTARY ENCODER CANOPEN

Interface

Configuration

The standard configuration of the encoder is: node number 32 and baud rate 20 Kbaud. For adapting the encoder for a respective application the customer could use SDO telegrams. Valid baud rate range is 20 kbaud up to 1Mbaud and node numbers from 0 to 127.

Remark: The encoder adds internal 1 to the adjusted node number.

Electrical interface

The standard connection is a cable with a RJ45 connector. 5 pin circular plug M12 and cable exit are available too (For pin assignment see table below).

Connection plan

Function	Wire end	Connector Pin RJ45	Connector Pin M12
Can High	white	1	4
Can Low	brown	2	5
Can-GND	green	3	1
GND	yellow	4	3
+ U _b = 10-30 V	red	8	2

Connectors (front view)

M12 Connector

MCD-XXXX-XXXX-XXXX-PAM

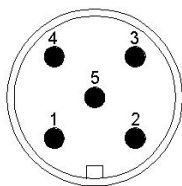

5 pin M12 connector male

Axial Cable Exit (*)

MCD-XXXX-XXXX-XXXX-CAW

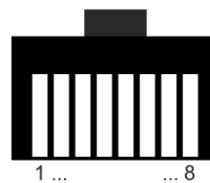

RJ45 Connector

(*) A RJ45 Connector is mounted on the cable end for the CAW version. This connector can be used for test purposes also for custom installation. Do not connect to any Ethernet network, devices may be damaged!

DATASHEET

ABSOLUTE MAGNETIC ROTARY ENCODER CANOPEN

Programmable Encoder - Parameter

Operating Parameters	This parameter determines the counting direction, in which the output code increases or decreases. As an important operating parameter the code sequence (complement) can be programmed.
Resolution per Revolution	The parameter resolution per revolution is used to program the desired number of steps per revolution.
Total Resolution	This parameter is used to program the desired number of measuring units over the total measuring range. This value may not exceed the total resolution of the absolute rotary encoder. If the encoder is used in a continuous measuring application, certain rules for the setting of this parameter must be followed. These rules are outlined in the manual.
Preset Value	The preset value is the desired position value, which should be reached at a certain physical position of the axis. The position value is set to the desired process value by the parameter pre-set.
Limit Switch, Min. and Max.	Two position values can be programmed as limit switches. By reaching these values one bit of the 32-bit process value is set to high.
Cam	Eight position values can be programmed as cams. By reaching these values bits in object 6300h Cam state register are set.

Programmable CAN Transmission Modes

Polled Mode	By a remote-transmission-request telegram the connected host calls for the current process value. The absolute rotary encoder reads the current position value, calculates eventually set-parameters and sends back the obtained process value by the same identifier.
Cyclic Mode	The absolute rotary encoder transmits cyclically - without being called by the host - the current process value. The cycle time can be programmed in milliseconds for values between 1 ms and 65536 ms.
Sync Mode	After receiving a sync telegram by the host, the absolute rotary encoder answers with the current process value. If more than one node number (encoder) shall answer after receiving a sync telegram, the answer telegrams of the nodes will be received by the host in order of their node numbers. The programming of an offset-time is not necessary. If a node should not answer after each sync telegram on the CAN network, the parameter sync counter can be programmed to skip a certain number of sync telegrams before answering again.

ABSOLUTE MAGNETIC ROTARY ENCODER CANOPEN

Mechanical Models

For detailed drawings please refer our website as drawing, IGES Drawing and STEP 3D Model under [mechanical drawings](#) or contact us

Flange Types

Synchro Flange

MCD-XXXX-XXXX-S060-XXX

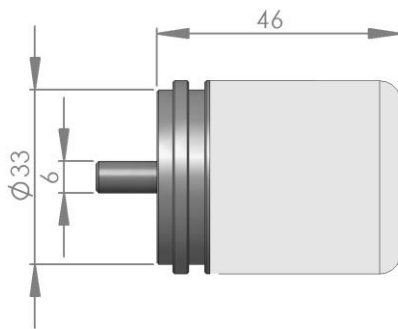

Blind Hollow Shaft

MCD-XXXX-XXXX-B060-XXX

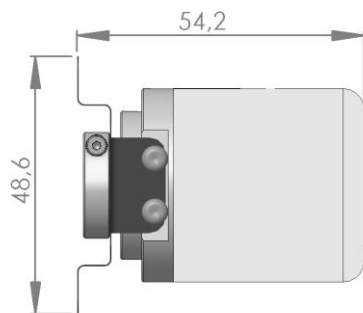

Clamp Flange

MCD-XXXX-XXXX-C100-XXX

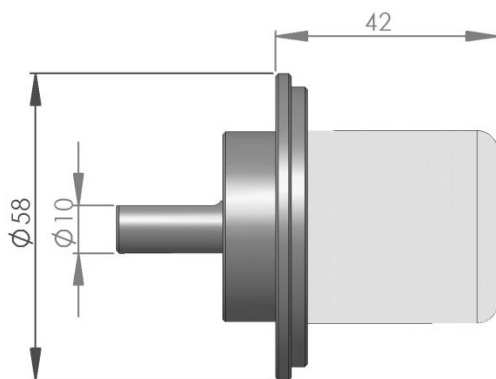

Housing and Connector Types

Axial Cable Exit

MCD-XXXX-XXXX-XXXX-CAW

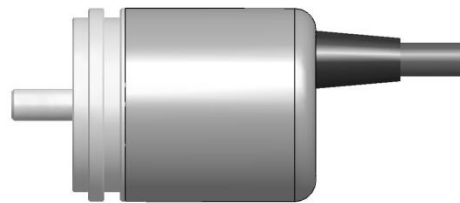

M12 Connector

MCD-XXXX-XXXX-XXXX-PAM

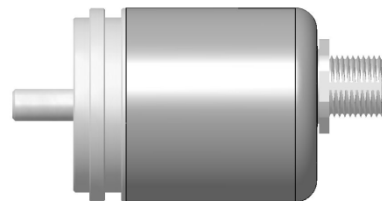

Axial Cable Exit with Gland

MCD-XXXX-XXXX-XXXX-GAW



All units measured in [mm]

DATASHEET

ABSOLUTE MAGNETIC ROTARY ENCODER CANOPEN

Models / Ordering Description

Description

Magnetocode	MCD-	__	00	B	-	__	__	-	__	0-	__
Interface and Version	CANopen	CA									
	CANopen lift (DSP417)	CL									
Current Version	CA		00								
	CL		00								
Code	Binary										
Bits for Revolutions	Single turn										00
	Multi turn (4096 turns)										12
	Multi turn (32768 turns)										15
Steps per revolution	4096										12
Flange	Synchro flange (6mm shaft diameter)								S		06
	Blind hollow shaft (6mm shaft diameter)								B		06
	58mm Clamping Flange (10mm shaft diameter)								C		10
Shaft diameter	06 mm (Flange S and B)										
	10 mm (Flange C)										
Mechanical options	Without										0
	Customized										C
Connection	Cable exit, axial 1m, moulded										CAW
	Cable exit, axial 1m, with cable gland										GAW
	Connector 5pol M12										PAM

Standard = bold, further models on request

Ordering example:

MCD-CA00B-1512-S060-CAW

Accessories

Article No	Article	Description
34050515	PAM5	Female cable connector M12x1 5pin A-coded for MCD-...-PAM
10001978	PAM5 2m	Connecting cable PAM5 2m shielded for MCD-...-PAM

Disclaimer

© FRABA AG, all rights reserved. We do not assume responsibility for technical inaccuracies or omissions. Specifications are subject to change without notice.

ABSOLUTE MAGNETIC ROTARY ENCODER CANOPEN

APPENDIX

Same Encoder Series also available ...

... with Serial SSI Interface. Please check for Documentation online : [magnetic rotary encoder with SSI Interface](#)



... or combined with a draw wire adapter to perform linear measurements, please check for Documentation online : [linear measurement with draw wire sensor](#)

