

POSITAL

FRABA

ABSOLUTE ROTARY ENCODER CANOPEN



CANopen

Main Features

- Compact and heavy-duty industrial design
- Interface: CANopen / CAN
- Housing: 58 mm Ø
- Solid / hollow shaft: 6 or 10 mm Ø / 15 mm Ø
- Through hollow shaft: 12 mm Ø
- Max. 65536 steps per revolution (16 Bit)
- Max. 16384 revolutions (14 Bit)
- Velocity- and Acceleration- output
-

Mechanical Structure

- Aluminium flange and housing
- Stainless steel shaft
- Optional: Stainless steel flange/ housing
- Precision ball bearings with sealing or cover rings
- Code disc made of unbreakable and durable plastic

Software Features

- Direction of rotation (complement)
- Resolution per revolution
- Total resolution
- Preset value
- Two limit switches and eight cams
- Baud rate and CAN-identifier
- Transmission mode: Polled mode, cyclic mode, sync mode
- Layer Setting Services
-

Electrical Features

- Temperature insensitive IR-opto-receiver-asic with integrated signal conditioning
- Connection cap: Status indication with two LEDs
- Polarity inversion protection
- Over-voltage-peak protection

ABSOLUTE ROTARY ENCODER CANOPEN

Technical Data

Electrical Data

Interface	Transceiver according to ISO 11898, galvanically isolated by opto-couplers
Transmission rate	max. 1 MBaud
Device addressing	Programmable via SDO telegrams Encoder with Connection Cap (OCC): Additional adjustable by rotary switches in connection cap
Supply voltage	10 – 30* V DC (absolute limits)
Current consumption	Multiturn: max. 70 mA with 10 V DC, max. 35 mA with 24 V DC Singleturn: max. 60 mA with 10 V DC, max. 30 mA with 24 V DC
Power consumption	max. 2.5 Watts
Step frequency LSB	800 kHz
Accuracy of division	$\pm \frac{1}{2}$ LSB (12 bit), ± 2 LSB (16 bit)
EMC	Emitted interference: EN 61000-6-4
	Noise immunity: EN 61000-6-2
Electrical lifetime	$> 10^5$ h

*Absolute rotary encoders should be connected only to subsequent electronics whose power supplies comply with EN 50178 (protective low voltage)

POSITAL

FRABA

ABSOLUTE ROTARY ENCODER CANOPEN

Mechanical Data

Housing	Aluminum, Optional Stainless Steel			
Lifetime	Dependent on Shaft Version and Shaft Loading – Refer to Table			
Max. Shaft Load	Axial 40 N, Radial 110 N (9 lbs / 25 lbs)			
Moment of Inertia of Rotor	≤ 30 gcm ² (0.16 oz-in ²)			
Friction Torque	≤ 3 Ncm (4.2 oz-in) (without Shaft Sealing)			
RPM (Continuous Operation)	Single-Turn: max. 12,000 RPM			
	Multi-Turn: max. 6,000 RPM			
Shock (EN 60068-2-27)	≤ 100 g (Half Sine, 6 ms)			
Permanent Shock (EN 60028-2-29)	≤ 10 g (Half Sine, 16 ms)			
Vibration (EN 60068-2-6)	≤ 10 g (10 Hz ... 2000 Hz) ≤ 10 g (10 Hz ... 1,000 Hz) (with Connection Cap)			
Weight (Standard Version)	Single-Turn: ~300 g (~0.7 lbs) Multi-Turn: ~400 g (~0.9 lbs)			
Weight (with Connection Cap)	Single-Turn: ~500 g (~1.1 lbs) Multi-Turn: ~700 g (~1.5 lbs)			
Weight (Stainless Steel Version)	Single-Turn: ~400 g (~0.9 lbs) Multi-Turn: ~500 g (~1.1 lbs)			
Weight (Stainless Steel Version with Connection Cap)	Single-Turn: ~1,100 g (~2.4 lbs) Multi-Turn: ~1,200 g (~0.7 lbs)			
Flange	Synchro (S)		Clamp (C)	Hub shaft (B)
Shaft Diameter	6 mm (~0.236 in)	10 mm (~0.394 in)	10 mm (~0.394 in)	15 mm (~0.591 in)
Shaft Length	10 mm (~0.394 in)	20mm (~0.787 in)	20 mm (~0.787 in)	*

* Mating Shaft: min: 15 mm (~0.591 in) / max: 30 mm (~1.181 in)

ABSOLUTE ROTARY ENCODER CANOPEN

Minimum (mechanical) lifetime

Flange	Lifetime in 10 ⁸ Revolutions with F _a / F _r		
	40 N / 60 N 9 lbs / 13 lbs	40 N / 60 N 9 lbs / 13 lbs	40 N / 60 N 9 lbs / 13 lbs
C10 (Clamp flange 10 x 20)	240	240	240
S10 (Synchro flange 10 x 20)	210	210	210
S06 (Synchro flange 6 x 10) without shaft sealing	710	710	710

* S06 (Synchro Flange 6 x 10) with Shaft Sealing: max. 20 N Axial, 80 N Radial (5 lbs / 18 lbs)

Environmental Conditions

Operating temperature	- 40 ... + 85 °C (- 40 ... + 185 °F)*
Storage temperature	- 40 ... + 85 °C (- 40 ... + 185 °F)*
Humidity	98 % (No Condensation)
Protection class (EN 60529)	Casing Side: IP 65 Casing Side: IP 54 (Connector Exit Axial 9 Pin D-Sub) Shaft Side: IP 64 (Optional with Shaft Sealing: IP66)
Heavy Duty Protection class (EN 60529)	Casing Side: IP 67 Shaft Side: IP 66

* Cable Exit: - 30 ... + 70 °C (- 22 ... + 158 °F) (Static), - 5 ... + 70 °C (23 ... 158 °F) (Flexing)

ABSOLUTE ROTARY ENCODER CANOPEN

Interface

Configuration

The standard configuration of the encoder is: node number 32 and baudrate 20KBaud. For adapting the encoder for a respective application the customer could use SDO telegrams. Valid baudrate range is 20 kBaud up to 1MBaud and for the node number from 0 to 89.

Remark: The encoder adds internal 1 to the adjusted device address.

Electrical Interface

The POSITAL absolute rotary with cable- and connector-exit were designed in accordance to CiA normative DR303-1 Cabeling and connector pin assignment. There are various electrical connecting options like 5 pin M12 connector. The encoder can be connected in the following versions:

- 5 pin M12 male connector and one 5 pin M12 female
- 5 pin M12 connector and venting element
- 9 pin D-Sub connector or cable exit (not available for Heavy Duty version)

Signal	5 pin round connector pin number (male / female)	9 pin D-Sub connector pin number	open cable
Signal	Pin	Pin	
CAN Ground	1	3	green
24 V supply voltage	2	9	white
0 V supply voltage	3	6	brown
CAN High	4	7	yellow
CAN Low	5	2	pink

Tab.1 Signal Assignment Connector / Cable

5 pin M12 connector female/male

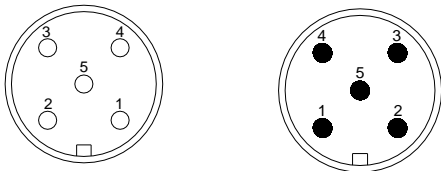

9 pin D-Sub-connector

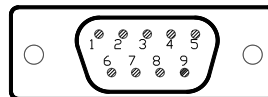

ABSOLUTE ROTARY ENCODER CANOPEN

Installation connection cap

The rotary encoder is connected with two or three cables depending on whether the power supply is integrated into the bus cable or connected separately. If the power supply is integrated into the bus cable, one of the cable glands can be fitted with a plug. The cable glands are suitable for cable diameters from 6.5 up to 9 mm.

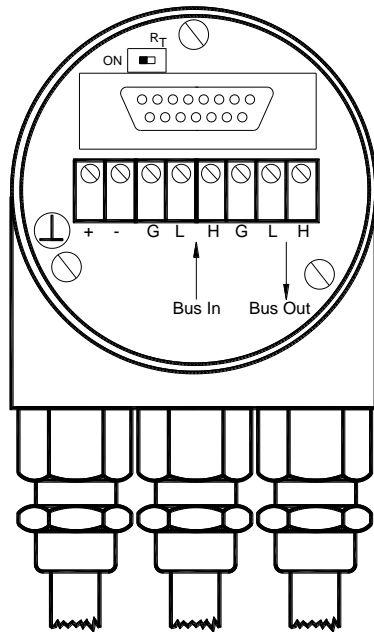

Configuration connection cap

The setting of the node number is achieved by 2 turn-switches in the connection cap. Possible addresses lie between 0 and 89 whereby every address can only be used once. **Inside the encoder the defined address is increased by one.** The connection cap can easily be opened for installation by removing the two cap screws.

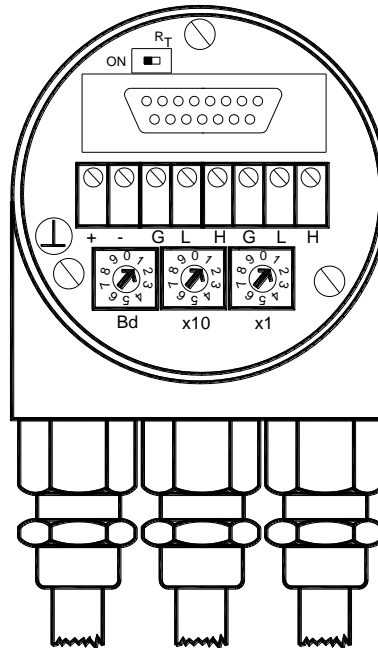

Clamp	Description
⊥	Ground
+	10..30 V Supply voltage
-	0 V Supply voltage
G (left)	CAN Ground (Bus In)
L (left)	CAN Low (Bus In)
H (left)	CAN High (Bus In)
G (right)	CAN Ground (Bus Out)
L (right)	CAN Low (Bus Out)
H (right)	CAN High (Bus Out)

A termination resistor is integrated in the connection cap. The resistor must be switched on if the encoder is connected at the end or at the beginning of the bus. Separation of Bus In and Bus Out signals if termination resistor is activated.

Resistor:



ABSOLUTE ROTARY ENCODER CANOPEN

Connection cap with round connector

This connection cap type has one or two 5 pin round connectors in M12 version. All other cable glands are replaced by blind caps.

Following table indicates pinning of the micro style connector:

Pin number	Signal
1	(CAN Ground)
2	10..30 V Supply voltage
3	0 V Supply voltage
4	CAN High
5	CAN Low

Bus In

5 pin circular connector M12
Pinning (Male)

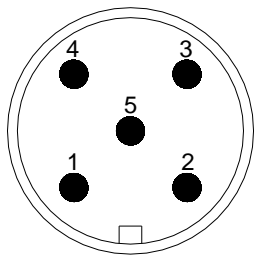

Diagnostic connection cap

Two LEDs on the backside of the connection cap show the operating status of the encoder.

This can be very useful for installing and setting-up the encoder

Bus Out

5 pin circular connector M12
Pinning (Female)

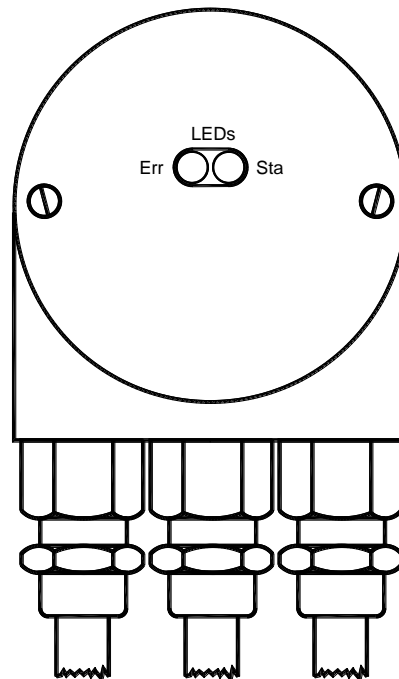
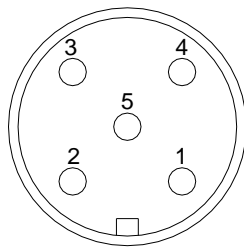

ABSOLUTE ROTARY ENCODER CANOPEN

Programmable Encoder - Parameter

Operating Parameters	This parameter determines the counting direction, in which the output code increases or decreases. As an important operating parameter the code sequence (complement) can be programmed.
Resolution per Revolution	The parameter resolution per revolution is used to program the desired number of steps per revolution.
Total Resolution	This parameter is used to program the desired number of measuring units over the total measuring range. This value may not exceed the total resolution of the absolute rotary encoder. If the encoder is used in a continuous measuring application, certain rules for the setting of this parameter must be followed. These rules are outlined in the manual.
Preset Value	The preset value is the desired position value, which should be reached at a certain physical position of the axis. The position value is set to the desired process value by the parameter pre-set.
Limit Switch, Min. and Max.	Two position values can be programmed as limit switches. By reaching these values one bit of the 32-bit process value is set to high.
Cam	Eight position values can be programmed as cams. By reaching these values bits in object 6300h Cam state register are set.

Programmable CAN Transmission Modes

Polled Mode	By a remote-transmission-request telegram the connected host calls for the current process value. The absolute rotary encoder reads the current position value, calculates eventually set-parameters and sends back the obtained process value by the same identifier.
Cyclic Mode	The absolute rotary encoder transmits cyclically - without being called by the host - the current process value. The cycle time can be programmed in milliseconds for values between 1 ms and 65536 ms.
Sync Mode	After receiving a sync telegram by the host, the absolute rotary encoder answers with the current process value. If more than one node number (encoder) shall answer after receiving a sync telegram, the answer telegrams of the nodes will be received by the host in order of their node numbers. The programming of an offset-time is not necessary. If a node should not answer after each sync telegram on the CAN network, the parameter sync counter can be programmed to skip a certain number of sync telegrams before answering again.

ABSOLUTE ROTARY ENCODER CANOPEN

Mechanical drawings: Connection cap encoder

Synchro flange (S)

Two versions available:

S06: Synchro flange with a shaft diameter of 6mm

S10: Synchro flange with a shaft diameter of 10mm

Synchro flange	d / mm	l / mm
Version S06	6 _{f6}	10
Version S10	10 _{h8}	20

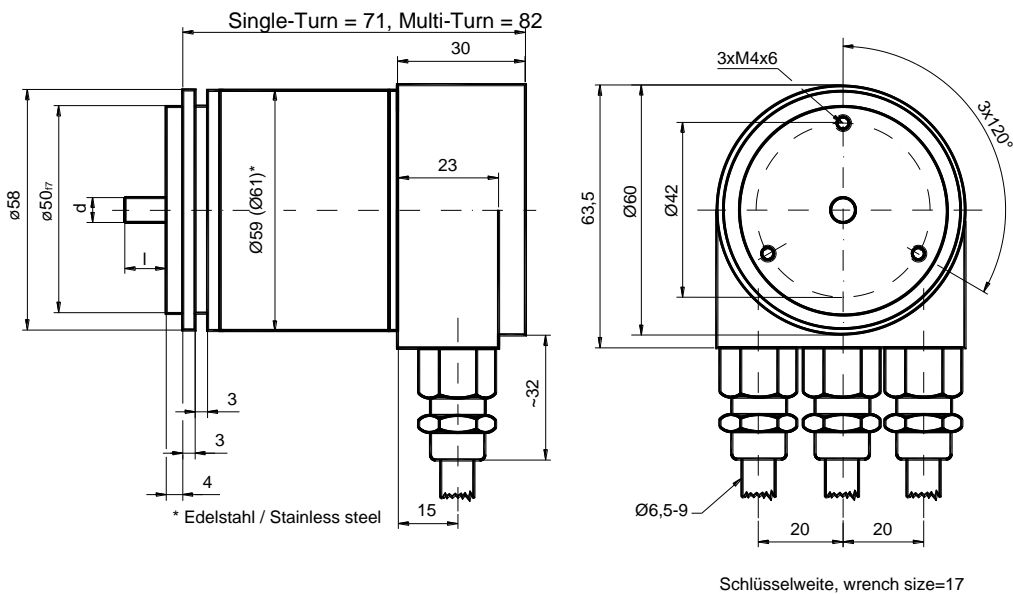

Clamp flange (C)

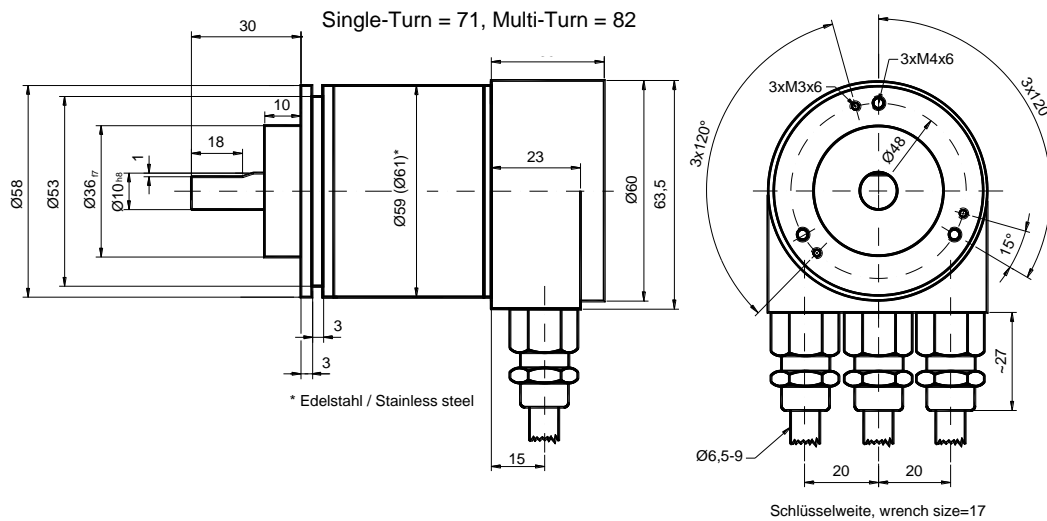

ABSOLUTE ROTARY ENCODER CANOPEN

Blind Hollow shaft (B)

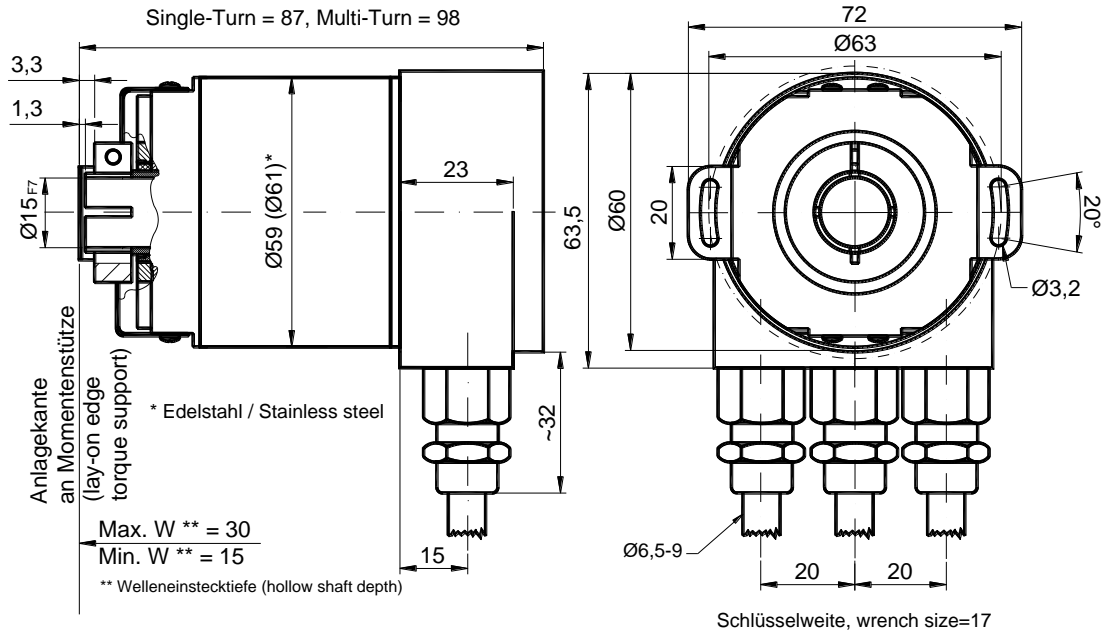

Mounting instructions

The clamp ring may only be tightened if the shaft of the driving element is in the hollow shaft.

The diameter of the hollow shaft can be reduced to 12mm, 10 mm or 8 mm by using an adapter (this reducing adapter can be pushed into the hollow shaft).

Maximum shaft movements of the drive element are listed in the table.

	axial	radial
static	± 0.3 mm	± 0.5 mm
dynamic	± 0.1 mm	± 0.2 mm

**ABSOLUTE ROTARY ENCODER
CANOPEN**

Connection cap AH58-B1CA-1BW, 5pin round connector M12, Micro style

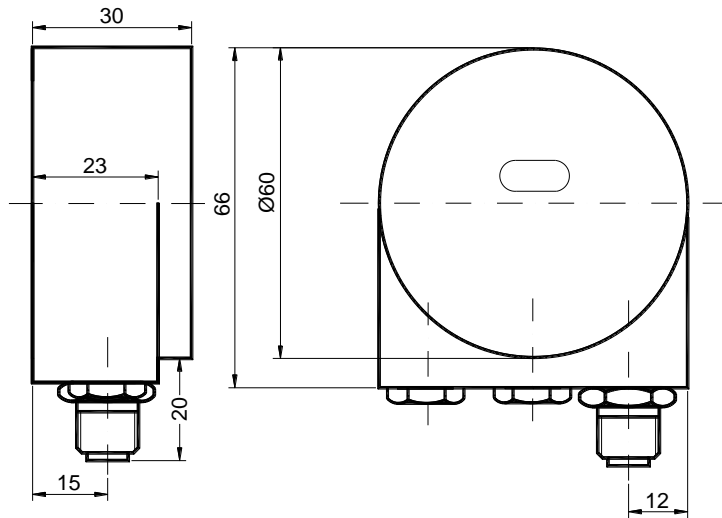

Connection cap AH58-B1CA-2BW, female and male connector 5pin connector M12, Micro Style

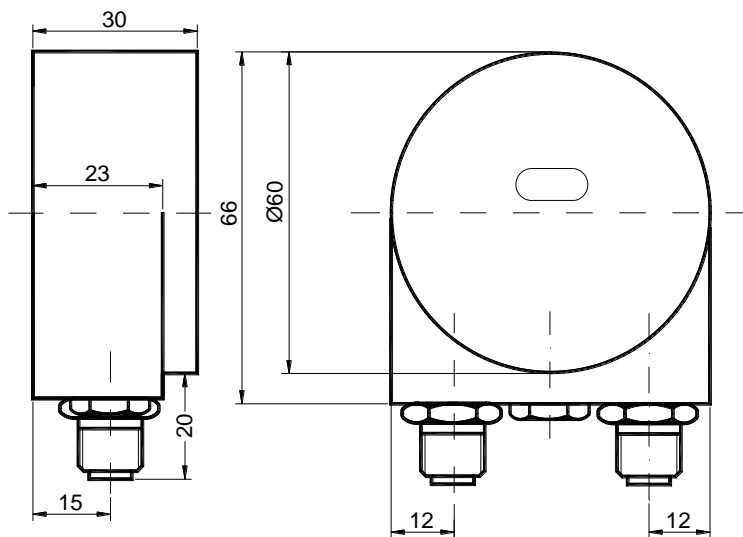

POSITAL

FRABA

ABSOLUTE ROTARY ENCODER CANOPEN

Synchroflange (S)

Two versions available

Cable exit (cable diameter = 8 mm)

Synchroflange	d / mm	l / mm
Version S06	6 _{f6}	10
Version S10	10 _{h8}	20

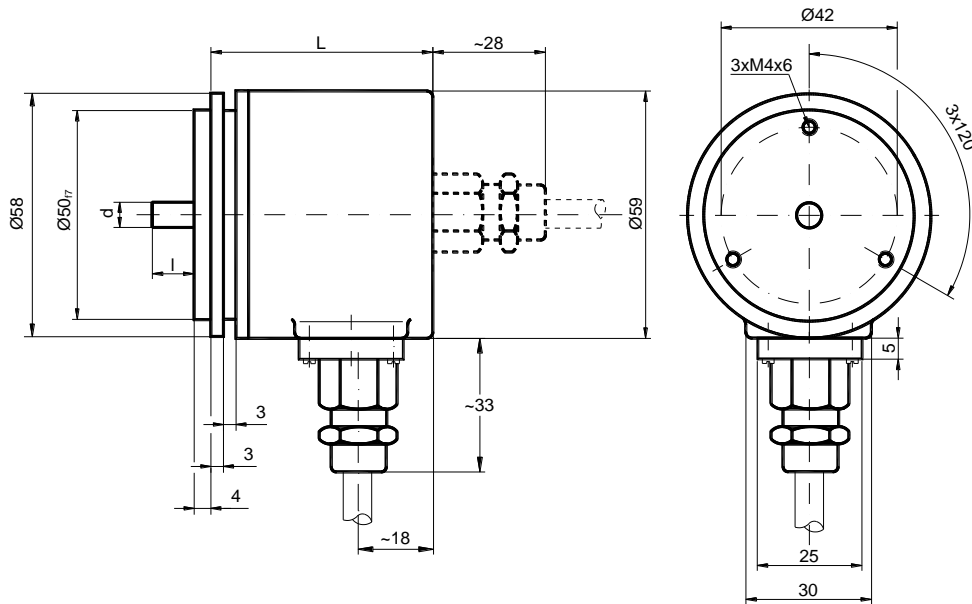

Clampflange (C10)

Cable exit (Cable diameter = 8 mm)

or 5 pin M12 connector

	L
Single-Turn	53mm
Multi-Turn	62mm

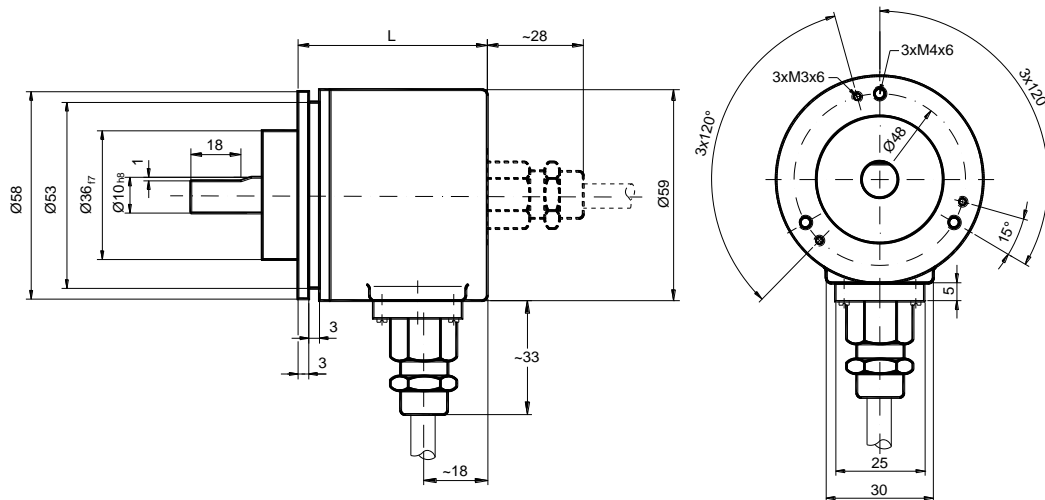

ABSOLUTE ROTARY ENCODER CANOPEN

Clampflange (C), 9 pin D-Sub connector

The dimensions of encoder housing in the versions cable exit, 12 pin circular connector and 5 pin connector from clamp flange are also valid for the synchro flange.

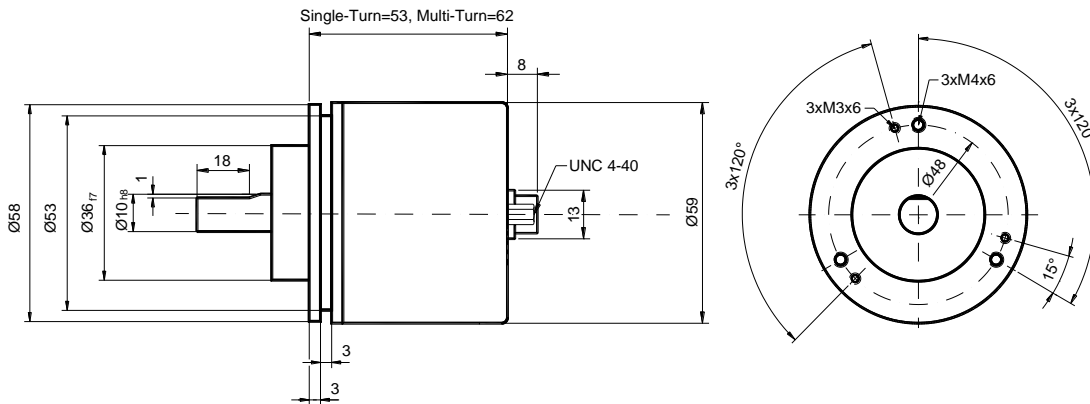

12 mm through hollow shaft (T), with M12-connector (optional with cable exit)

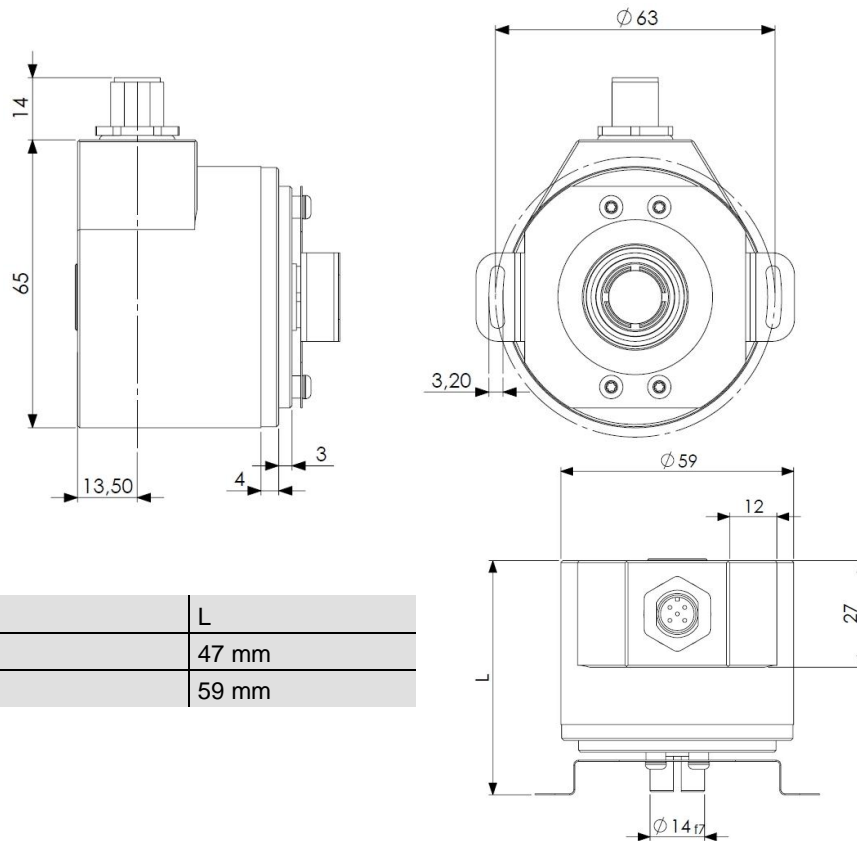

T120	L
Singleturn	47 mm
Multiturn	59 mm

ABSOLUTE ROTARY ENCODER CANOPEN

Blind hollow shaft (B)

Cable exit (cable diameter = 8 mm)
or 5 pin M12 connector

Connection (Cable/Connector)	L
Singleturn	53 mm
Multiturn	81 mm

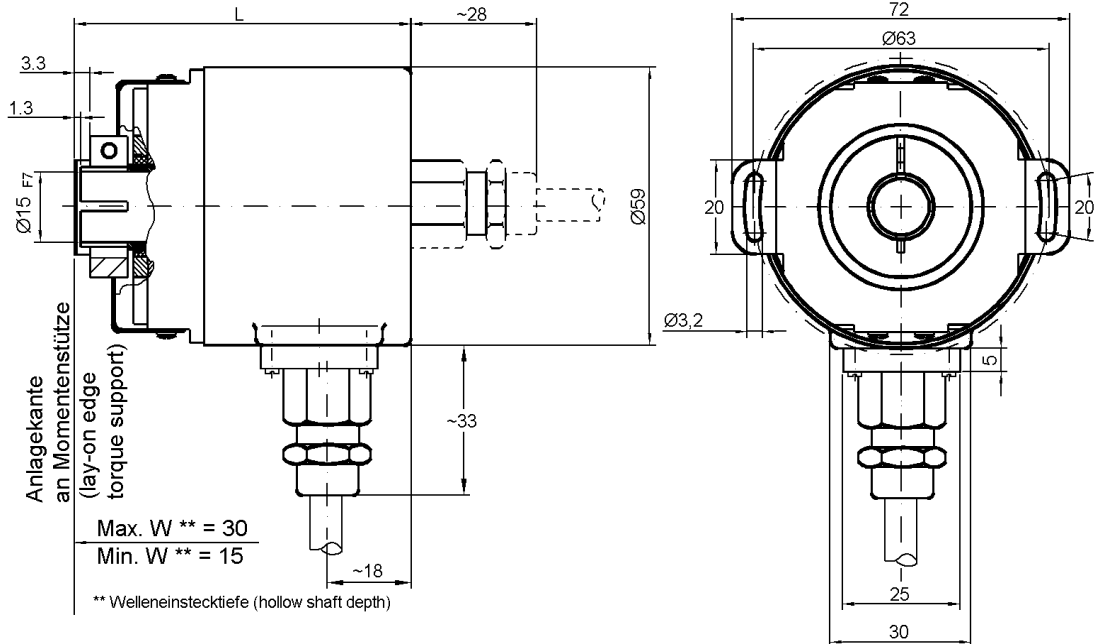

Mounting instructions

The clamp ring should only be tightened if the shaft of the driving element is inserted into the hub shaft.

The diameter of the hollow shaft can be reduced to 12mm, 10 mm or 8 mm by using an adapter (this reducing adapter can be pushed into the hollow shaft).

Maximum shaft movements of the drive element are listed in the table.

	Axial	Radial
static	± 0,3 mm	± 0,5 mm
dynamic	± 0,1 mm	± 0,2 mm

POSITAL

FRABA

ABSOLUTE ROTARY ENCODER CANOPEN

Models/Ordering Description

(Models/Ordering Description for Heavy Duty Version → see next side)

Description	Type key		
Optocode	OCD-	CA A1 B -	
Interface	CANopen	CA	
Version		A1	
Code	Binary	B	
Revolutions (Bits)	Singleturn		00
	Multiturn (4096 revolutions)		12
	Multiturn (16384 revolutions)		14
Steps per revolution	4096 (0,09°)		12
	8192 (0,04°)		13
	65536 (0,005°)		16
Flange	Clamp flange		C
	Synchro flange		S
	Through Hollow Shaft		T
	Blind shaft		B
Shaft diameter	06 mm		06
	10 mm		10
	12 mm (Through Hollow Shaft)		12
	15 mm (Blind Hollow shaft)		15
Mechanical options	without		0
	Shaft sealing (IP66)		S
	Stainless steel version*		V
	Customized		C
Connection			
Connection Caps	Cap encoder with connection cap AH 58-B1CA-3PG		H3P
	Cap encoder with connection cap AH 58-B1CA-2M20		H2M
	Cap encoder with connection cap AH 58-B1CA-1BW		H1B
	Cap encoder with connection cap AH 58-B1CA-2BW		H2B
	Cap encoder without connection cap**		HCC
Cable	Cable exit 1m, radial, open wire ends		CRW
	Cable exit 1m, axial, open wire ends		CAW
Connectors	Connector exit, radial, 5 pin male M12		PRM
	Connector exit, axial, 5 pin male M12		PAM
	Connector exit, axial, 9 pin D-Sub		PA9

ABSOLUTE ROTARY ENCODER CANOPEN

Standard = bold, further models on request

* Stainless Steel version is not available with radial cable or connector exit (namely CRW, PRM)

** For the function of the encoder a connection cap is needed. To order this encoder type only makes sense for spare part / replacement usage

Connection caps

All connections caps are equipped with a switchable terminal resistor, integrated T-coupler for CAN bus lines, BCD switches to adjust baudrate and node number, as well as LEDs for diagnosis.

Description	Article Name	Article Number
Aluminium housing with three M12 cable glands for cable diameters between 6,5 – 9 mm.	AH 58-B1CA-3PG	0246370325
Stainless steel housing with three M12 cable glands.	AH 58-B1CA-3PG-VA	0246370328
Aluminium housing with one 5 pin male M12 connector.	AH 58-B1CA-1BW	0246370342
Aluminium housing with one 5 pin male M12 connector and one 5 pin female M12 connector	AH 58-B1CA-2BW	0246370370
Aluminium housing with two M20 cable glands for cable diameter between 9 – 13 mm.	AH 58-B1CA-2M20	0246370339

ABSOLUTE ROTARY ENCODER CANOPEN

HEAVY DUTY



These „Outdoor encoder“ is suitable for harsh industrial environments. The heavy-duty option for the CANopen encoder provides a wide temperature range, protection elements against perspiration water inside the encoder and a heavy-duty housing. Uppermost attention was laid on a high EMI protection. Micro style connectors for power supply and bus-in / bus-out

connection allow easy installation of the encoder. The CANopen encoder can be configured with all available project tools by implementing the ESD file into the current project. The entire connection cap features, like node-addressing, baud rate setting and terminal resistor, are integrated and controllable via the CAN-Bus.

Main features

- Compact dimensions
- Heavy Duty housing
- Protective element against perspiration water
- Integrated connection cap features
 - T-coupler
 - Node number addressing
- baud rate setting
- terminal resistor
- Standard protection class:
 - IP66 shaft side
 - IP67 casing side

POSITAL

FRABA

ABSOLUTE ROTARY ENCODER CANOPEN

Heavy Duty version with solid shaft and Clamp flange(C)

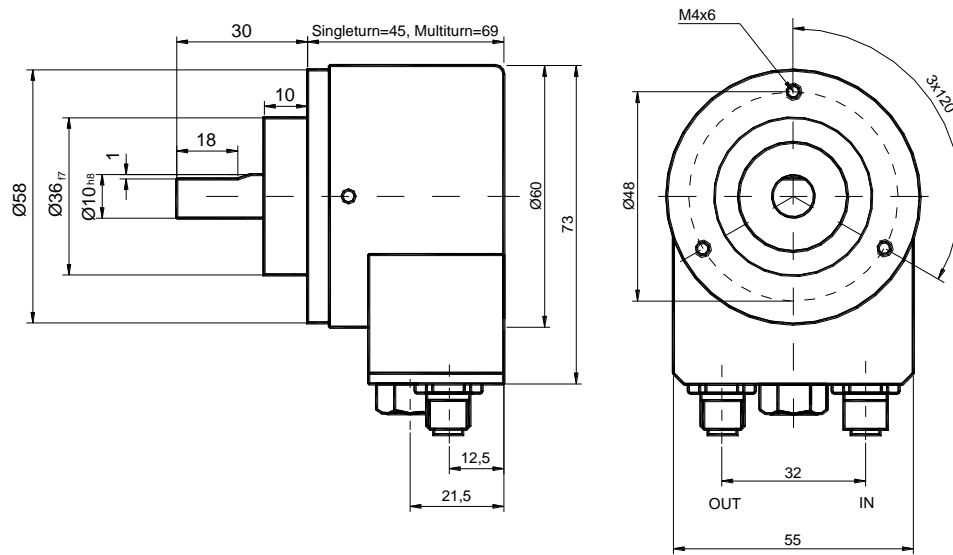

Heavy Duty version with blind shaft (B)

Maximum shaft movements of drive element are listed in the table.

	Axial	Radial
static	± 0,3 mm	± 0,5 mm
dynamic	± 0,1 mm	± 0,2 mm

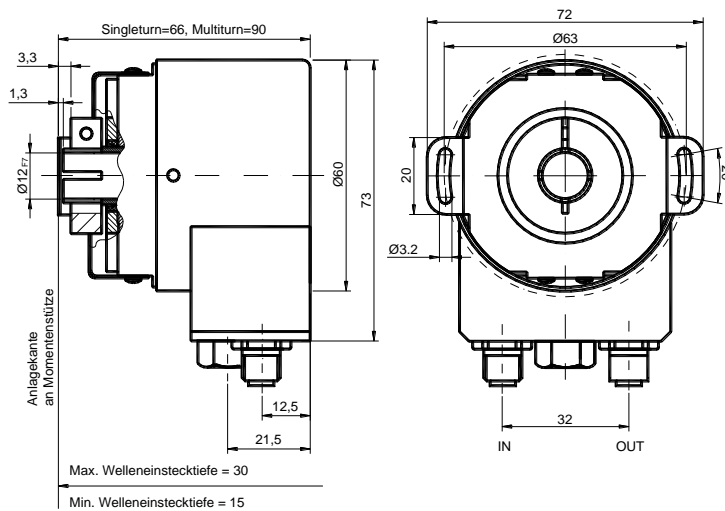

ABSOLUTE ROTARY ENCODER CANOPEN

Models/Ordering Description for Heavy Duty Version

Description	Type key							
Optocode	OCD-	CA	A1	B	-	-	-	-
Interface	CANopen	CA						
Version			A1					
Code	Binary			B				
Revolutions (Bits)	Singleturn							00
	Multiturn (4096 revolutions)							12
	Multiturn (16384 revolutions)							14
Steps per revolution	4096							12
	8192							13
	65536							16
Flange	Clamp flange							C
	Synchro flange							S
	Blind shaft							B
Shaft diameter	10 mm							10
	15 mm (Hollow shaft)							15
Mechanical options	Heavy Duty							H
	Customized							C
Connection	1x 5 pin M12 connector male, 1x 5 pin M12 connector female, venting element							PRN
	1x 5 pin M12 connector male, venting element							PRM

Accessories and documentation

Description		Article Name	Article Number
Shaft Coupling	Drilling: 10 mm / 10 mm	GS 10	29100450
	Drilling: 6 mm / 6 mm	GS 06	29100350
Clamp Disc	Set (4 pieces).	SP 15	32400155
Clamp Ring	Set (2 pieces)	SP H	32400152
Reducing Ring*	15 mm to 12 mm	RR 12	32220291
Reducing Ring *	15 mm to 10 mm	RR 10	32220292
Reducing Ring *	15 mm to 8 mm	RR 8	32220295

* only for hollow shaft (also available as stainless steel version)

Note: All datasheets and manuals can be downloaded for free from our website www.posital.eu

We do not assume responsibility for technical inaccuracies or omissions. Specifications are subject to change without notice.