

POSITAL

FRABA

ABSOLUTE ROTARY ENCODER DEVICE NET



Main Features

- Compact and Heavy-Duty Industrial Model
- Certified: By ODVA
- Interface: Device Net
- Housing: 58 mm Ø
- Full or Hub Shaft: 6 or 10 mm Ø / 15 mm Ø
- Max. 65536 Steps per Revolution (16 Bit)
- Max. 16384 Revolutions (14 Bit)
- Code: Binary
- UL Listed

Mechanical Structure

- Aluminum Flange and Housing
- Stainless Steel Shaft
- Sealed Precision Ball Bearings
- Unbreakable and Durable Polycarbonate Code Disc

Programmable Parameters

- Direction of Rotation (Complement)
- Resolution per Revolution
- Total Resolution
- Preset Value
- Transmission Mode:
Polled Mode, Change of State, Cyclic

Electrical Features

- Status Indication with Two LEDs in the Connection Cap
- Temperature Insensitive IR-Opto-ASIC with Integrated Signal Conditioning
- Monitored Integrated IR-Illumination
- Reliable SMD and FPGA Technology
- Polarity Inversion Protection
- Over-Voltage-Peak Protection

ABSOLUTE ROTARY ENCODER DEVICE NET

Technical Data

Electrical Data

Interface	Transceiver According ISO/DIS 11898, up to 64 Nodes Galvanically Isolated by Opto-Couplers
Transmission Rate	150 kBaud, 250 kBaud, 500kBaud
Device Addressing	Adjustable by Rotary Switches in Connection Cap
Supply Voltage	10 - 30 V DC (Absolute Limits)*
Current Consumption	max. 230 mA with 10 V DC, max. 100 mA with 24 V DC
Power Consumption	max. 2.5 Watts
Step Frequency LSB	800 kHz
Accuracy of Division	$\pm \frac{1}{2}$ LSB (12 Bit), ± 2 LSB (16 Bit)
EMC	Emitted Interference: EN 61000-6-4
	Noise Immunity: EN 61000-6-2
Electrical Lifetime	$> 10^5$ h

* Supply Voltage According to EN 50 178 (Safety Extra-Low Voltage)

Mechanical Data

Housing	Aluminum, Optional Stainless Steel			
Max. Shaft Load	Axial 40 N, Radial 110 N (9 lbs / 25 lbs)			
Moment of Inertia of Rotor	$\leq 30 \text{ gcm}^2$ (0.16 oz-in ²)			
Friction Torque	$\leq 3 \text{ Ncm}$ (4.2 oz-in) (without Shaft Sealing)			
RPM (Continuous Operation)	Single-Turn: max. 12,000 RPM, Multi-Turn: max. 6,000 RPM			
Shock (EN 60068-2-27)	$\leq 30 \text{ g}$ (Half Sine, 11 ms)			
Permanent Shock (EN 60028-2-29)	$\leq 10 \text{ g}$ (Half Sine, 16 ms)			
Vibration (EN 60068-2-6)	$\leq 10 \text{ g}$ (10 Hz ... 1,000 Hz)			
Weight (Standard Version)	Single-Turn: ~550 g (~1.2 lbs)			
	Multi-Turn: ~600 g (~1.3 lbs)			
Weight (Stainless Steel Version)	Single-Turn: ~1,100 g (~2.4 lbs)			
	Multi-Turn: ~1,200 g (~2.6 lbs)			
Flange	Synchro (S)		Clamp (C)	
Shaft Diameter	6 mm (~0.236 in)	10 mm (~0.394 in)	10 mm (~0.394 in)	Hub Shaft (B) 15 mm (~0.591 in)
	10 mm (~0.394 in)	20 mm (~0.787 in)	20 mm (~0.787 in)	*

* Mating Shaft: min: 15 mm (~0.591 in) / max: 30 mm (~1.181 in)

ABSOLUTE ROTARY ENCODER DEVICE NET

Minimum (Mechanical) Lifetime

Flange	Lifetime in 10 ⁸ Revolutions with F _a / F _r		
	40 N / 60 N 9 lbs / 13 lbs	40 N / 80 N 9 lbs / 18 lbs	40 N / 110 N 9 lbs / 25 lbs
C10 (Clamp Flange 10 x 20)	240	100	40
S10 (Synchro Flange 10 x 20)	210	90	30
S6 (Synchro Flange 6 x 10) without Shaft Sealing*	710	300	110

* S6 (Synchro Flange 6 x 10) with Shaft Sealing: max. 20 N Axial, 80 N Radial (5 lbs / 18 lbs)

Environmental Conditions

Operating Temperature	- 40 ... + 85 °C (- 40 ... + 185 °F)*
Storage Temperature	- 40 ... + 85 °C (- 40 ... + 185 °F)*
Humidity	98 % (No Condensation)
Protection Class (EN 60529)	Casing Side: IP 65
	Shaft Side: IP 64 (Optional with Shaft Sealing: IP66)

* Cable Exit: - 30 ... + 70 °C (- 22 ... + 158 °F) (Stationary), - 5 ... + 70 °C (23 ... 158 °F) (Flexing)

ABSOLUTE ROTARY ENCODER DEVICE NET

Interface

Installation

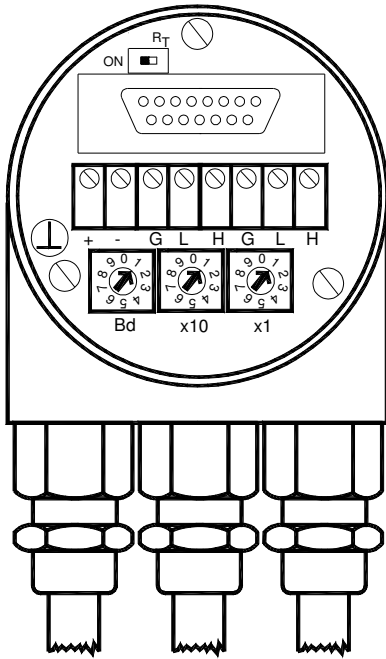

The rotary encoder is connected by three cables. The power supply is achieved with a two-wire connection cable through one PG 9. Each one of the twisted-pair and shielded bus lines are guided in and out through two PG 9 on the right side (as seen on clamps)

Clamp	Description
⊥	Ground
+	24 V Supply Voltage
-	0 V Supply Voltage
CG	CAN Ground
CL	CAN Low
CH	CAN High
CG	CAN Ground
CL	CAN Low
CH	CAN High

There is a resistor provided in the connection cap, which must be used as a line termination on the last device

Resistor:



The setting of the node number is achieved by 2 turn-switches in the connection cap. Possible addresses lie between 0 and 63 whereby every address can only be used once. 2 LEDs on the back-side of the connection cap show the operating status of the encoder.

ABSOLUTE ROTARY ENCODER DEVICE NET

Cabel

Pin	Signal	Description	Color
1	V-	GND	Black
2	CAN-L	CAN Bus Signal (Dominant Low)	Blue
3	CAN-H	CAN Bus Signal (Dominant High)	White
4	V+	External Voltage Supply Vcc	Red

Connector

Pin	Signal	Description	Color
2	V+	External Voltage Supply Vcc	Red
3	V-	GND	Black
4	CAN-H	CAN Bus Signal (Dominant High)	White
5	CAN-L	CAN Bus Signal (Dominant Low)	Blue

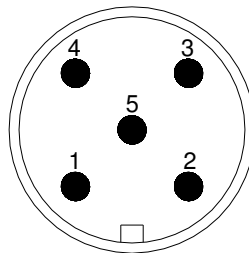

5 pin connector

ABSOLUTE ROTARY ENCODER DEVICE NET

Interface

Programmable Encoder - Parameter

Operating Parameters	As operating parameters the code sequence (complement) can be programmed. This parameter determines the counting direction, in which the output code increases or decreases.
Resolution per Revolution	The parameter resolution per revolution is used to program the desired number of steps per revolution. Each value between 1 and 4,096 can be programmed.
Total Resolution	This parameter is used to program the desired number of measuring units over the total measuring range. This value may not exceed the total resolution of the absolute rotary encoder. If the encoder is used in a continuous measuring application, certain rules for the setting of this parameter must be followed. These rules are outlined in the manual.
Preset Value	The preset value is the desired position value, which should be reached at a certain physical position of the axis. The position value is set to the desired process value by the parameter pre-set.

Programmable Transmission Modes

Polled Mode	By a telegram the connected host calls for the current process value. The absolute rotary encoder reads the current position value, calculates eventually set-parameters and sends back the obtained process value by the same identifier.
Change of State	The absolute rotary encoder transmits the actual process value. The process value is transmitted when the position changes. This is useful to reduce the bus activity.
Cyclic	The absolute rotary encoder transmits the actual process value event controlled by an internal timer. This is also useful to reduce the bus activity.

ABSOLUTE ROTARY ENCODER DEVICE NET

Mechanical Drawings (all dimensions in mm)

Synchro Flange (S)

available in 2 versions

Synchro Flange	d / mm	l / mm
Version S06	6 _{f6}	10
Version S10	10 _{h8}	20

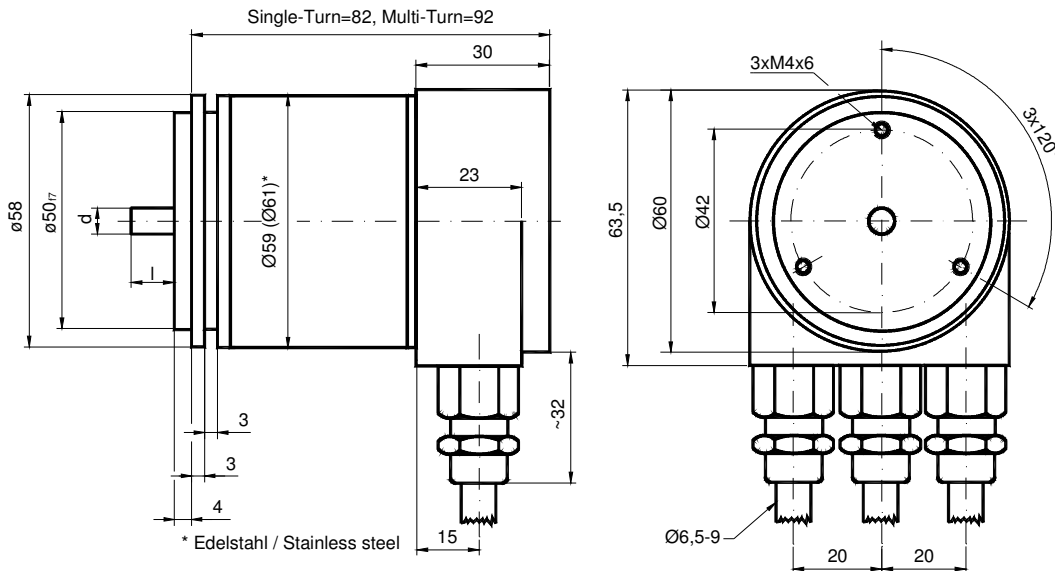

Schlüsselweite, wrench size=17

Clamp Flange (C)

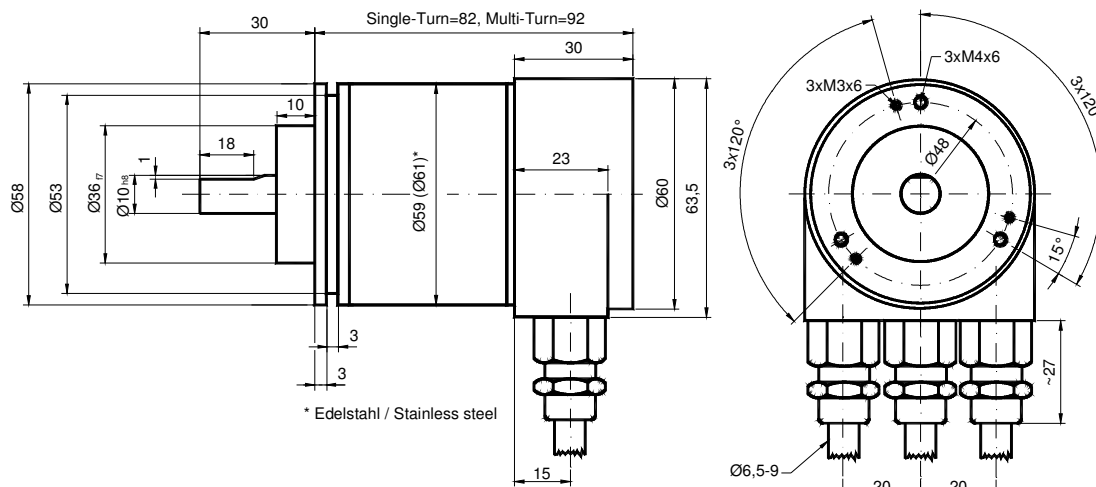

Schlüsselweite, wrench size=17

ABSOLUTE ROTARY ENCODER DEVICE NET

Hub Shaft (B)

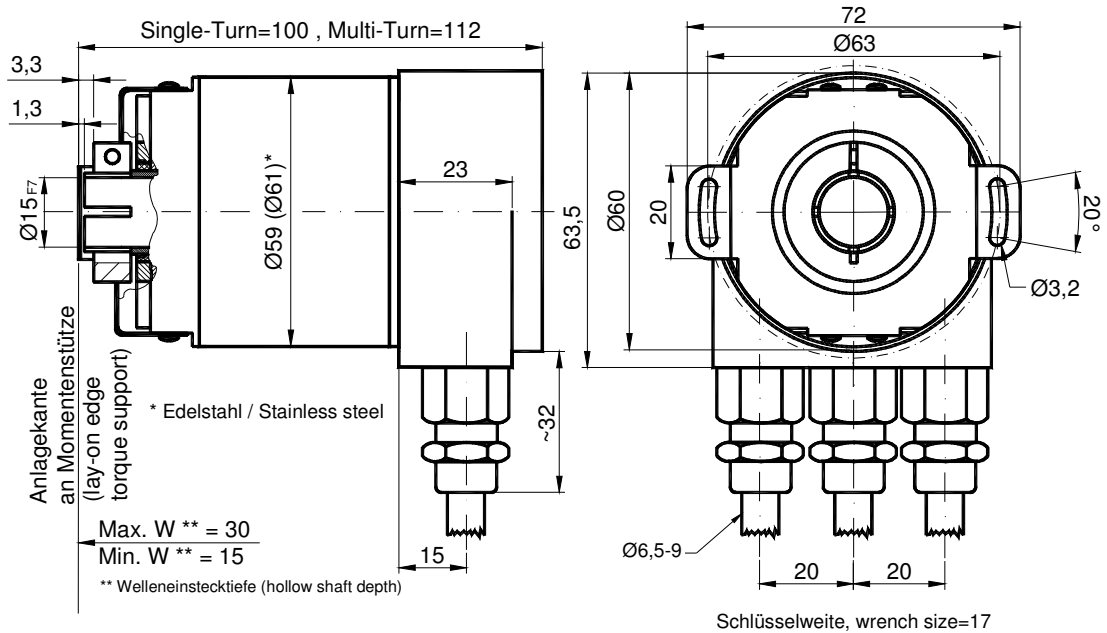

Mounting Instructions

The clamp ring may only be tightened if the shaft of the driving element is in the hub shaft.

The diameter of the hub shaft can be reduced to 12mm, 10 mm or 8 mm by using an adapter (this reducing adapter can be pushed into the hub shaft).

Allowed shaft movements of the drive element are listed in the table.

	Axial	Radial
Static	± 0.3 mm (~0.012 in)	± 0.5 mm (~0.020 in)
Dynamic	± 0.1 mm (~0.004 in)	± 0.2 mm (~0.008 in)

ABSOLUTE ROTARY ENCODER DEVICE NET

Connection cap with 5pin round connector,
Micro style

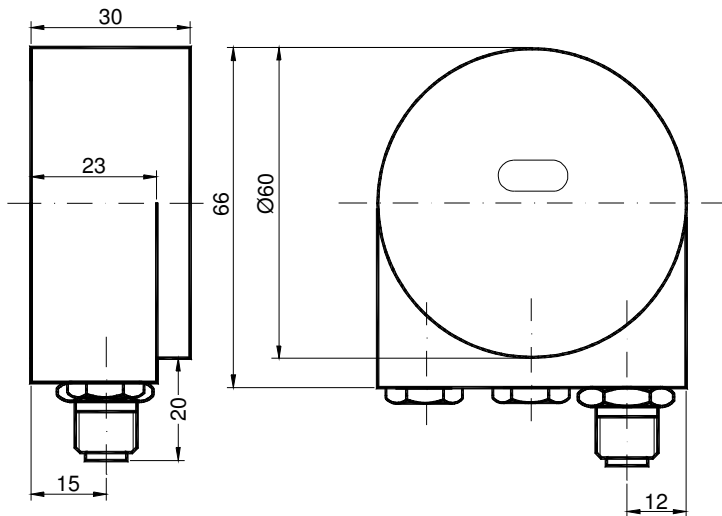

Square Flange (Q)

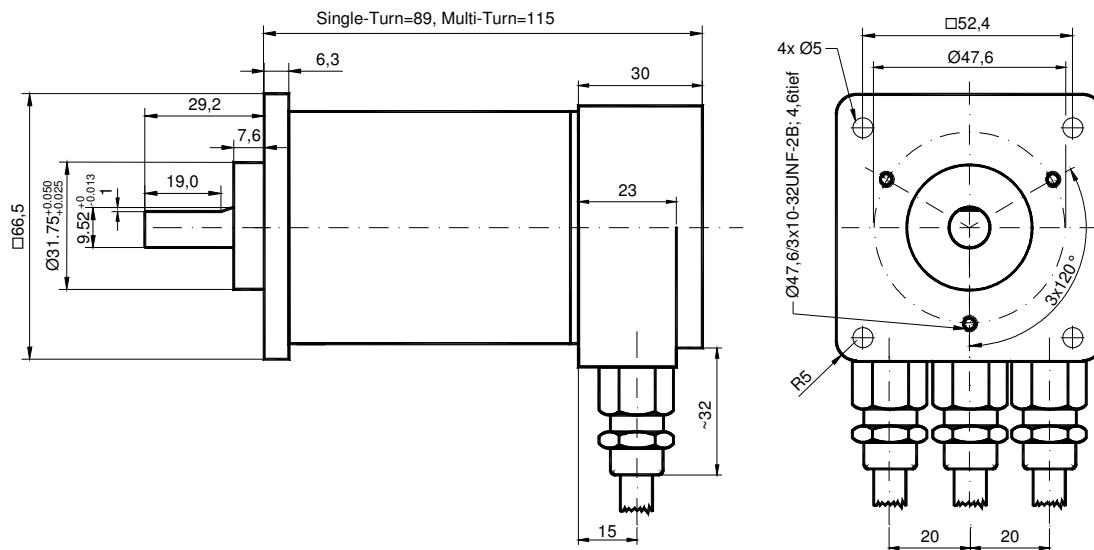

ABSOLUTE ROTARY ENCODER DEVICE NET

Synchro Flange (S)

Two types available

Synchro Flange	d / mm	l / mm
Typ S06	6 _{f6}	10
Typ S10	10 _{h8}	20

Cable (cable diameter = 8 mm)

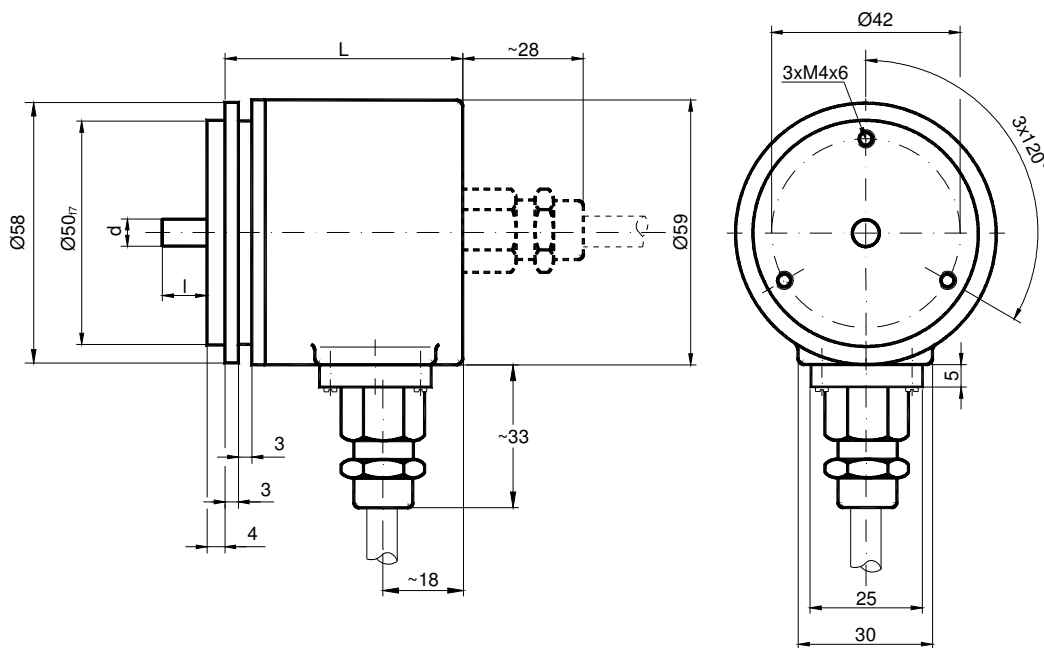

		L in mm
Single-Turn	Axial	53
	Radial	53
Multi-Turn	Axial	62
	Radial	62

ABSOLUTE ROTARY ENCODER DEVICE NET

Clamp Flange (C)

Cable (cable diameter = 8 mm)

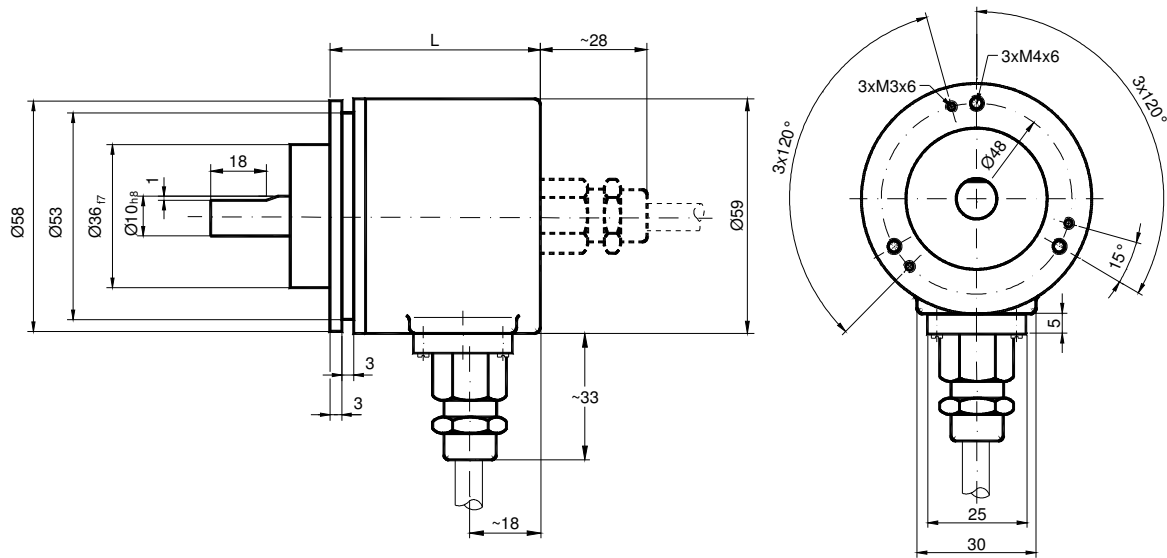

		L in mm
Single-Turn	Axial	53
	Radial	53
Multi-Turn	Axial	62
	Radial	62

ABSOLUTE ROTARY ENCODER DEVICE NET

Clamp Flange (C), 5 Pin Connector

The dimensions of the housing from type Clamp flange 5 pin connector are the same like the type synchro flange.

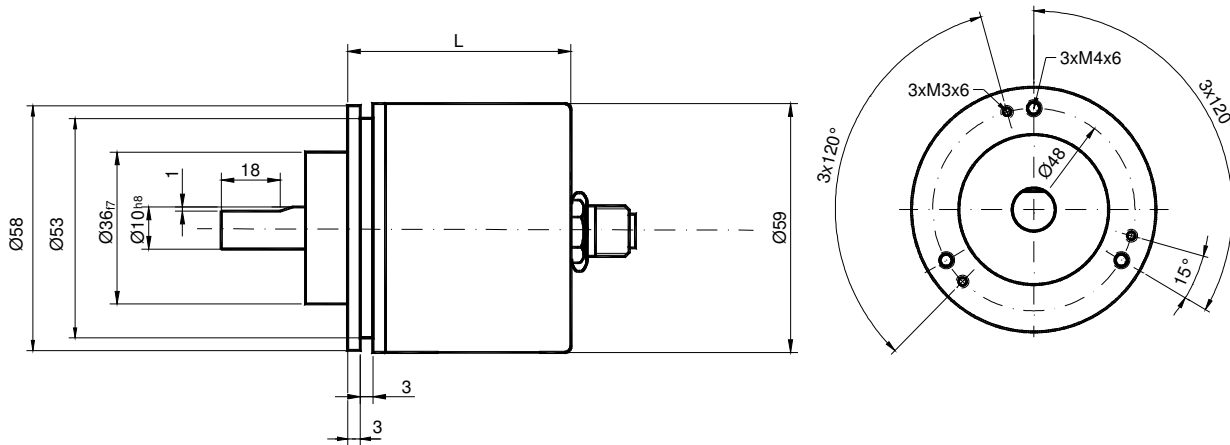

		L in mm
Single-Turn	Axial	53
	Radial	53
Multi-Turn	Axial	62
	Radial	62

ABSOLUTE ROTARY ENCODER DEVICE NET

Hub Shaft (B)

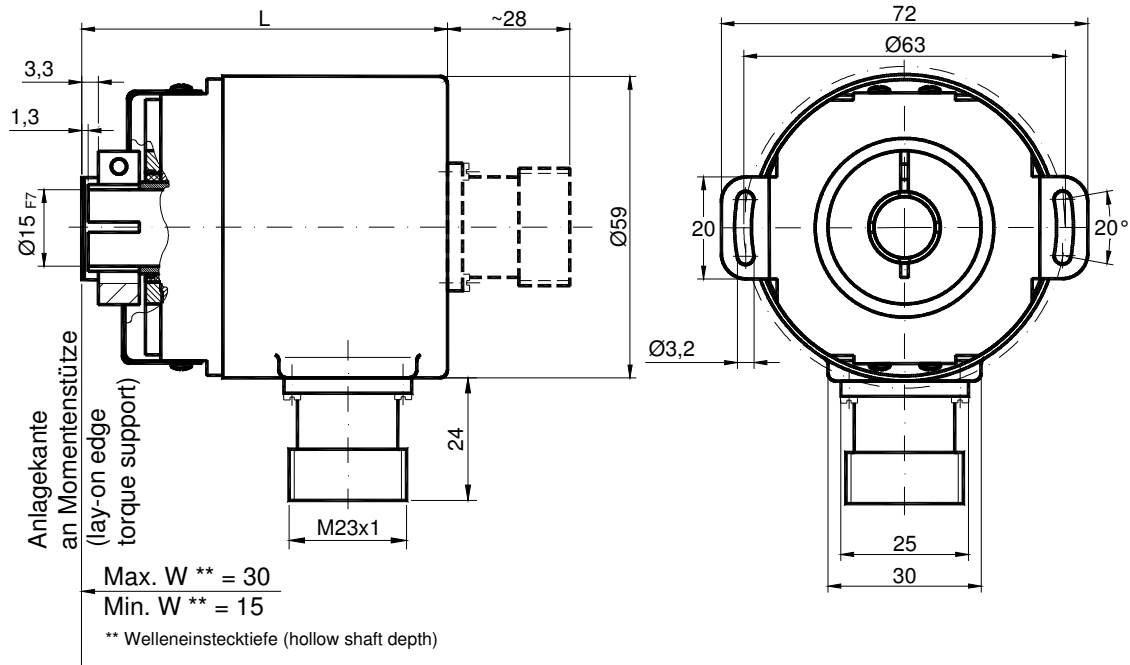

		L
Single-Turn	Axial	72
	Radial	72
Multi-Turn	Axial	81
	Radial	81

Mounting Instructions

The clamp ring may only be tightened if the shaft of the driving element is in the hub shaft.

The diameter of the hub shaft can be reduced to 12mm, 10 mm or 8 mm by using an adapter (this reducing adapter can be pushed into the hub shaft).

Allowed shaft movements of the drive element are listed in the table.

	Axial	Radial
Static	± 0.3 mm (~0.012 in)	± 0.5 mm (~0.020 in)
Dynamic	± 0.1 mm (~0.004 in)	± 0.2 mm (~0.008 in)

ABSOLUTE ROTARY ENCODER DEVICE NET

Heavy Duty version with full shaft

Clamp flange available in two versions.

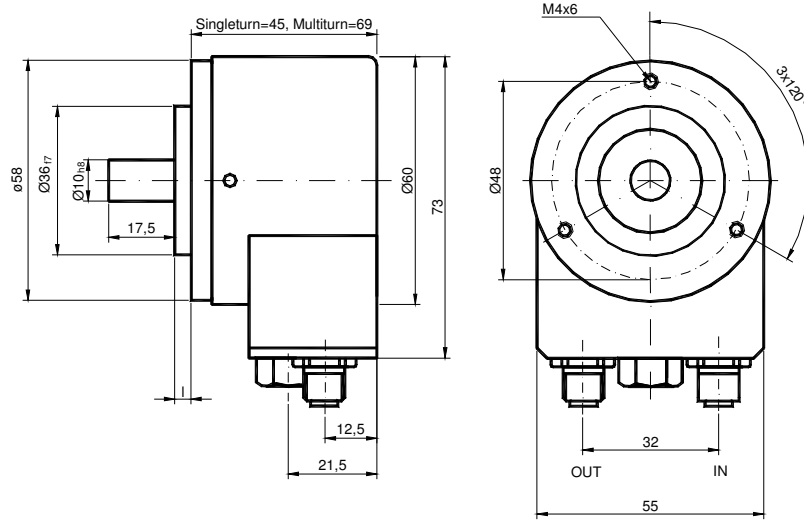

Heavy Duty version with hub shaft

Allowed shaft movement of drive element is listed in the table.

	Axial	Radial
Static	± 0.3 mm (~0.012 in)	± 0.5 mm (~0.020 in)
Dynamic	± 0.1 mm (~0.004 in)	± 0.2 mm (~0.008 in)

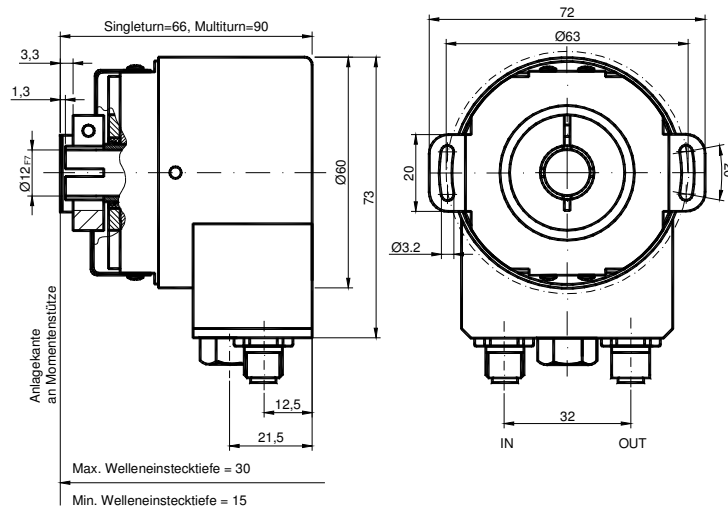

ABSOLUTE ROTARY ENCODER DEVICE NET

Versions / Ordering Description

Description	Type Key									
Optocode	OCD-	D2	B1	B -	--	--	-	--	-	OCC
Interface	DeviceNet	D2								
Version			B1							
Code	Binary			B						
	Single-Turn									00
Revolutions (Bits)	Multi-Turn (4096 Revolutions)									12
	Multi-Turn (16384 Revolutions)									14
Steps per Revolution (Bits)	4096									12
	8192									13
	65536									16
Flange	Clamp Flange									C
	Synchro Flange									S
	Hub Shaft									B
	Square Flange									Q
Shaft Diameter	10 mm									10
	06 mm									06
	15 mm (Hub Shaft)									15
Mechanical Options	Without									0
	Shaft Sealing (IP66)									S
	Stainless Steel Version									V
	Heavy Duty									H
	Customized									C
Connection	Connection Cap*									OCC
	Connector, 5-pin, M12, Radial									PRM
	Connector, 5-pin, M12, Axial									PAM
	Cable ; Radial (1m)									CRW
	Cable ; Axial (1m)									CAW
	Heavy Duty									PRN

* The connection cap has to be ordered separately!

Standard = Bold, Further Models on Request

All types UL-listed

ABSOLUTE ROTARY ENCODER DEVICE NET

Connection Caps

	Description	Type
Standard DeviceNet	T-Coupling-Functionality with Integrated Address Setting	AH 58-B1DA-3PG
	Stainless Steel Configuration	AH 58-B1DA-3PG-VA
	Connection with 5pin Round Connector, Micro Style M12	AH 58-B1DA-1BW
Alternative Version DeviceNet	2 Cable Glands for Cable Diameter: 9 - 13 mm	AH 58-B1DA-2M20

Accessories and Documentation

Description		Type
Shaft Coupling**	Diameter: 10 mm	GS 10
	Diameter: 6 mm	GS 06
Clamp Disc**	4 pcs. / OCD	SP 15
Clamp Ring**	2 pcs. / OCD	SP H
Reducing Adapter ***	15 mm to 12 mm (to ~0.472 in)	RR12
	15 mm to 10 mm (to ~0.394 in)	RR10
	15 mm to 8 mm (to ~0.315 in)	RR8
User Manual*	Installation and Configuration Manual, German	UMD-DA
	Installation and Configuration Manual, English	UME-DA
EDS-File*	Disc Containing EDS-file for Configuration (for OCC).	OCD-DN-C
	Disc Containing EDS-File for Configuration.	OCD-DN-0

*** Only for Hub Shaft

** Needless for Hub Shaft

Note: All datasheets and manuals can be downloaded for free from our website www.posital.com

We do not assume responsibility for technical inaccuracies or omissions. Specifications are subject to change without notice.