



ABSOLUTE ROTARY ENCODER  
WITH ETHERNET POWERLINK INTERFACE  
POWERLINK PROTOCOL VERSION 1 AND 2  
USER MANUAL

### **ETHERNET POWERLINK USER MANUAL**

#### **Imprint**

FRABA Inc.  
1800 East State Street, Suite 148  
Hamilton, NJ 08609  
USA  
Phone +1 609 750 8705  
Fax. +1 609 750 8703  
[www.posital.com](http://www.posital.com)  
[info@posital.com](mailto:info@posital.com)

#### **Copyright**

The company FRABA POSITAL claims copyright on this documentation. It is not allowed to modify, to extend, to hand over to a third party and to copy this documentation without written approval by the company FRABA POSITAL. Nor is any liability assumed for damages resulting from the use of the information contained herein. Further, this publication and features described herein are subject to change without notice.

#### **Alteration of Specifications reserved**

Technical specifications, which are described in this manual, are subject to change due to our permanent strive to improve our products.

#### **Document information**

Documentname: UMUS-OCD-EP  
Versionnummer: 05/09  
Author: Klaus Matzker

#### **Service-Phone**

For technical support, questions and suggestions for improving our products and documentations call our telephone line: +49/221/96213-0

### ETHERNET POWERLINK USER MANUAL

<p><b>1 Introduction .....4</b></p> <p>1.1 Absolute Rotary Encoders .....4</p> <p>1.2 Ethernet .....5</p> <p>1.3 TCP/IP .....5</p> <p>1.4 UDP .....6</p> <p><b>2 Hardware set-up and Ethernet Connection ....7</b></p> <p>2.1 Network Topology .....7</p> <p>2.2 Connecting an Absolute Encoder.....8</p> <p>2.3 Ethernet Cables .....8</p> <p>2.3.1 RJ45 – M12 crossed .....8</p> <p>2.3.2 RJ45 – M12 straight .....8</p> <p>2.3.3 M12 – M12 crossed.....8</p> <p>2.4 Diagnostic LED's.....9</p> <p><b>3 Network Configuration ..... 10</b></p> <p><b>4 Project integration ..... 11</b></p> <p><b>5 Powerlink protocol Version 1..... 12</b></p> <p>5.1 Powerlink cycle ..... 12</p> <p>5.2 Powerlink messages ..... 13</p> <p><b>6. Powerlink protocol Version 2..... 18</b></p> <p>6.1 Powerlink cycle ..... 18</p> <p>6.2. Encoder Profile ..... 19</p> <p>Object 6000h: Operating parameters..... 19</p> <p>Object 6001h: Measuring units per revolution.....20</p> <p>Object 6002h: Total measuring range in measuring units.....20</p> <p>Object 6003h: Preset value.....20</p> <p>Object 6004h: Position value .....20</p>	<p>Object 6500h: Operating status .....20</p> <p>Object 6501h: Single-turn resolution .....21</p> <p>Object 6502h: Number of distinguishable revolutions.....21</p> <p>Object 6504h: Supported alarms.....21</p> <p>Object 6506h: Supported warnings .....21</p> <p>6.3. Web applet.....22</p> <p>Main Controller Site.....23</p> <p>E-mail and Network Configuration.....24</p> <p><b>7 Glossary.....25</b></p> <p><b>8 History.....26</b></p>
---	---

### ETHERNET POWERLINK USER MANUAL

## 1 Introduction

### 1.1 Absolute Rotary Encoders

Absolute rotary encoders provide a definite value for every possible rotary position. All these values are reflected on one or more code discs. The beams of infrared LEDs are sent through the code discs and detected by Opto-Arrays. The output signals are electronically amplified and the resulting value is transferred to the interface.

The absolute rotary encoder has a maximum resolution of 65,536 steps per revolution (16 Bit). The Multi-Turn version can detect up to 16,384 revolutions (14 Bit). Therefore the largest resulting resolution is 30 Bit =  $2^{30} = 1,073,741,824$  steps. The standard Single-Turn version has 13 Bit, the standard Multi-Turn version 25 Bit.

The encoder sends the data in decimal code via standard or fast Ethernet (100 Base T). At present it supports the following protocol: Ethernet Powerlink with protocol version 1.

The encoder is able to provide as output data the position value without further calculation

A Powerlink managing node, operating as master, must be in a network to read out the process data from the encoder.

### ETHERNET POWERLINK USER MANUAL

#### 1.2 Ethernet

The present developments in the field of Industrial Ethernet are based on the vision of an integrated access of all data of a company through a uniform communication system. In higher levels of enterprise communication Ethernet is the main medium of data transfers. Combined with other IT technologies it is internationally standardized. In the long run automation engineers will benefit from the rapid technological progress in the mass markets of IT and web technologies.

Ethernet technically provides a system with higher data transfer rates than common field bus systems. TCP/IP and UDP do have a statistical access method to access the medium thereby prohibiting determined response times. Many developments are intensely done on additional real time mechanisms, e.g. Ethernet Powerlink

#### 1.3 TCP/IP

Even though Ethernet and TCP/IP are often used together and sometimes used interchangeably, these are three different kinds of terms and you should carefully separate them. The coherences are based on the ISO/OSI reference model after ISO/IEC 7498 that is needed to basically understand these terms.

Ethernet only describes layer 1 and 2 in this model, nevertheless the term is often used in error in engineering as description of all layers between 1 and 7.

The IP protocol of layer 3 was developed in the 70's by the US military (MIL-STD 1777). It allows a universal addressing independent of the hardware involved in heterogeneous networks. It also manages the transfer of large packets by splitting them up into smaller packets. The well-known TCP protocol (MIL-STD 1778) ensures a reliable data transfer.

HTTP (RFC 2068) and SMTP (MIL-STD 1781) belong to layer 7 of the OSI model and allow to transfer data and documents via web browser or to send e-mails.

### ETHERNET POWERLINK USER MANUAL

#### 1.4 UDP

User Datagram Protocol is utilized to send data that does not need to be transferred in a reliable way. The UDP packet is encapsulated in an IP packet which in turn is encapsulated in a PPP packet. Both UDP and IP have checksum octets and the PPP packet has its FCS octets however this can only guarantee that the data and the destination are correct. If a packet is lost, it will not be resent using UDP, this issue is only addressed by the TCP protocol.

#### 1.5 OSI-Modell

Layer			
7	Application Layer	SMTP, FTP, HTTP	Application
6	Presentation Layer		
5	Session Layer		
4	Transport Layer	TCP and UDP	Data transport
3	Network Layer	IP and IPX	
2	Data Link Layer	Ethernet	
1	Physical Layer	10BASET, 100BASET	Cable

### ETHERNET POWERLINK USER MANUAL

## 2 Hardware set-up and Ethernet Connection

### 2.1 Network Topology

Using Ethernet there are different kinds of topologies possible. The connection of the encoder can be made directly to a hub. If you use a direct connection to a computer without network components in between, you need to use a

standard, "straight" network cable (not a crossover cable). You need at least a cable of category 5 to get a data transfer rate up to 100 Mbit.

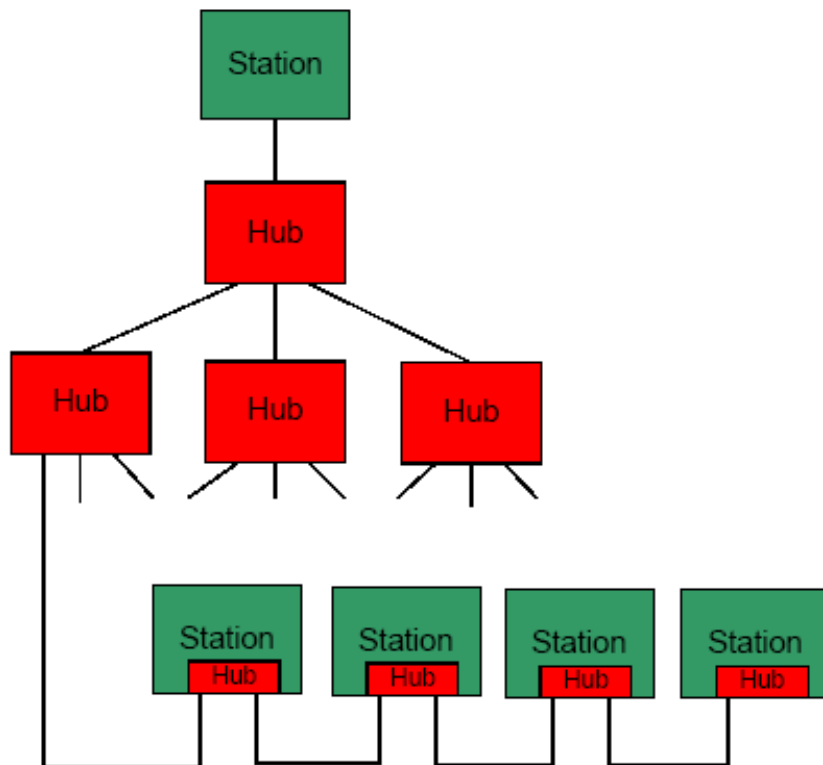

The symbolized structure shows a classic star topology and a line cabling structure. With encoder version 00 you must directly connect the encoder device to a hub. An integrated hub in encoder version A1 offers both: star or more useful a line structure.

Only hubs should be used because of low frame jitter and latency time. For fulfilling time requirements up to 10 hubs can be connected together with a maximum cable length of 100m.

These requirements are specified in Powerlink specification. For more details visit the web site: [www.ethernet-powerlink.org](http://www.ethernet-powerlink.org).

### ETHERNET POWERLINK USER MANUAL

#### 2.2 Connecting an Absolute Encoder

The encoder is connected by a 5 pin M12 connector for the power supply and one 4 pin, D-coded M12 connector for Ethernet.

##### Connector Ethernet

4 pin female, D-coded

Pin Number	Signal
1	Tx +
2	Rx +
3	Tx -
4	Rx -

Sketch on encoder view

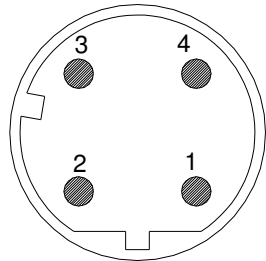

Encoder version A1 uses a second D-coded connector and provides an integrated hub functionality. On or in the packaging of the connector is the mounting description.

##### Connector power supply

5 pin male, A-coded

Pin Number	Signal
1	+24 V
2	+24 V
3	0 V
4	0 V
5	PE

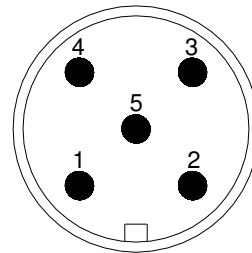

#### 2.3 Ethernet Cables

##### 2.3.1 RJ45 – M12 crossed

Signal	RJ45 Pin	M12 Pin	Signal
Tx+	1	2	Rx+
Tx-	2	4	Rx-
Rx+	3	1	Tx+
Rx-	6	3	Tx-

##### 2.3.2 RJ45 – M12 straight

Signal	RJ45 Pin	M12 Pin	Signal
Tx+	3	1	Tx+
Tx-	6	3	Tx-
Rx+	1	2	Rx+
Rx-	2	4	Rx-

##### 2.3.3 M12 – M12 crossed

Signal	M12 Pin	M12 Pin	Signal
Tx+	1	2	Rx+
Tx-	3	4	Rx-
Rx+	2	1	Tx+
Rx-	4	3	Tx-

### ETHERNET POWERLINK USER MANUAL

#### 2.4 Diagnostic LED's

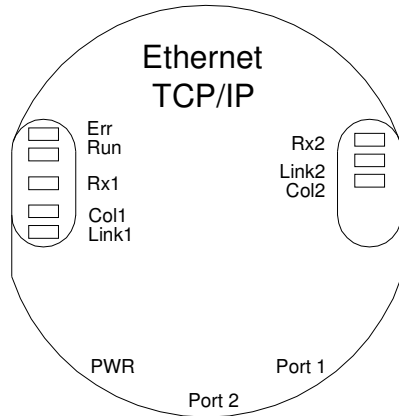

LED	Color	Description for LED = on
Rx1	Yellow	Incoming and outgoing traffic for port 1
Link1	Green	Link to another Ethernet component for port 1
Collosion1 *	Red	Ethernet collisions on the bus for port 1
Rx2 *	Yellow	Incoming and outgoing traffic for port 2
Link2 *	Green	Link to another Ethernet component for port 2
Collosion2 *	Red	Ethernet collisions on the bus for port 2
Error *	Red	Reserved
Run *	Green	Reserved

\* Only for version A1

### ETHERNET POWERLINK USER MANUAL

#### 3 Network Configuration

The rotary encoder can be used either with the Ethernet Powerlink IP address which can be programmed or the wired IP 10.10.10.10. A switch to choose corresponding option is located in the connection cap. If the switch 2 is in position "off", the POWERLINK IP has been chosen (default!).

##### **Powerlink Protocol version 1:**

**The encoder is pre-configured with a fixed Powerlink node number 100, which cannot be changed by the user. Be aware of this restriction!** The hex coded rotary switches cannot be found in the cap as shown in the picture.

The function of the DIP switch can be used if another than EPL IP address is needed or the user is not sure about a programmed node IP.

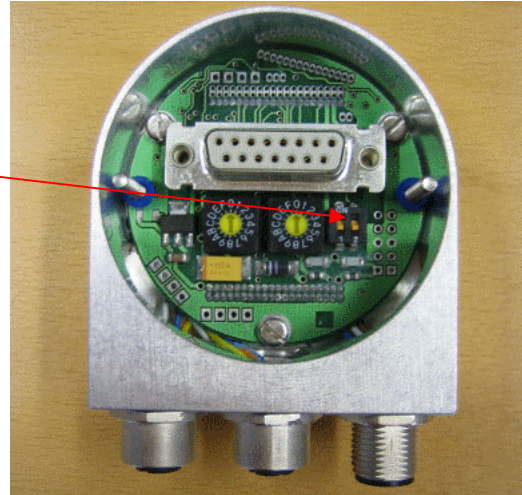

##### **Encoder version A1:**

Both Hex rotary switches are used to configure the Powerlink (EPL) node address. Allowed address range for a controlled node is: 1-239.

### ETHERNET POWERLINK USER MANUAL

#### 4 Project integration

This integration description is related to B&R control units and automation studio.

For adding an encoder into your project a generic Powerlink device is needed. So you have to add the library 'POWERLNK' first and use a generic device. To realize a data connection the following information must be configured for the generic device (here: encoder):

- Controlled node number
- Offset for the data pointer within data frame
- Length of data type

The Powerlink encoder with

- **EPL protocol V1** has currently a fixed node number 100
- **EPL protocol V2** has got a pre-configured node number 110 at factory.

There is no data offset in the EPL frame, because only one process value is used: position value. The data length is 8 bytes whereby only 4 bytes contain really updated values. All other bytes are set to 0. Ordered data bytes of a read position value within a EPL frame is low byte first and at

DB1	DB2	DB3	DB4	DB5	DB6	DB7	DB8
LSB			MSB	00	00	00	00

least MSB.

#### Position value coding:

#### Data exchange direction:

The encoder offers only IN Data as Poll Response message (PRes). No data out messages contained within Poll Request (PReq) message can be transmitted to the encoder.

### ETHERNET POWERLINK USER MANUAL

## 5 Powerlink protocol Version 1

### 5.1 Powerlink cycle

The Powerlink protocol offers an isochronous communication. A deterministic transmission is a requirement out of high performance applications. The deterministic network cycle is achieved with a time slot principle, which is described in following picture. An EPL cycle is divided into 4 periods: Start, Isochronous, Asynchronous, Idle Period.

With Start period the devices latch their process data. This action is synchronous realized via the whole EPL network.

Isochronous period: CN are processed what means that the MN node request the nodes after each other. In this time slot the process values are transmitted.

Asynchronous period: Used for non time critical data.

Idle period: Remaining time till next cycle. Used to compensate different processing cycle times to achieve an outside constant cycle time.

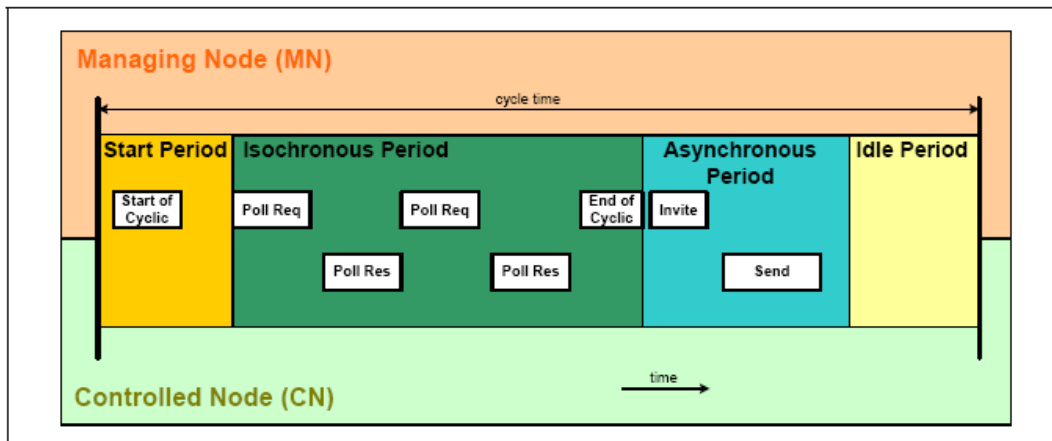

### ETHERNET POWERLINK USER MANUAL

#### 5.2 Powerlink messages

Ethernet Powerlink frames are embedded in a standard Ethernet frame. Because of that it is possible to use standard diagnostic tools in an EPL network. But you must be aware, that a standard PC can be able to interrupt the controlled EPL cycle. As a result the cycle can not be deterministic anymore.

The Ethernet frame is divided into 3 parts: Ethernet standard header, Ethernet powerlink part as standard Ethernet data and annex. For destina-

tion and source address within Ethernet standard header the MAC address is given. A MAC address is built up with 6 bytes, here are the first 5 bytes constant: 00-60-65-00-49., the sixth octet is the node number. The Ethernet type field is set to: xxxx.

Powerlink specific data:

See the marked entries, which are fixed for all other EPL frames. The rest is defined depending on the specific service identifier (message type).

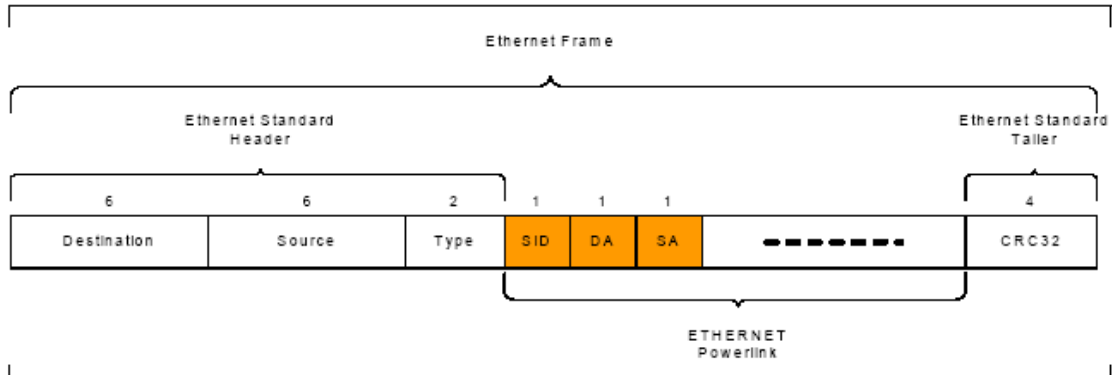

Code	Name	Description
SID	Service identifier	Identifies the additional reference data.
DA	Destination Address	Node which the frame is sent to.
SA	Source Address	Node which sent the frame.

Service number	Description	Transfer type	Comment
1	Start of Cyclic (SoC)	Broadcast	Marks begin of EPL cycle and isochronous part.
2	End of Cyclic (EoC)	Broadcast	Marks end of isochronous part
3	Poll Request (PReq)	Unicast	Transfer request of MN to CN to send isochronous data. CN answers with PollResponse frame. Frame can include data from MN to CN.
4	Poll Response (PRes)	Broadcast	Contains isochronous data of a CN.
5	Acyclic Invite (AInv)	Unicast	Frame in asynchronous part for MN to request asynchronous data from a particular CN.
6	Acyclic Send (ASnd)	Unicast/Broadcast	Frame in asynchronous part of the cycle to send asynchronous data (to a CN or to the MN).
7			Reserved

## ETHERNET POWERLINK USER MANUAL

### 5.2.1 Powerlink messageSoC

This message is sent as a broadcast telegram to all CN on the network. All devices will sample on receiving this telegram their input state. The encoder is latching in this moment the current position value. Total number of transmitted bytes is 64 octets, according to Ethernet standard framing. If you compare the given table below with the

information from chapter 5.2 you can see, that the first three entries are out of the EPL frame. Grey colored area is specific data according to the SoC message.

The structure of the frame is given in the following picture.

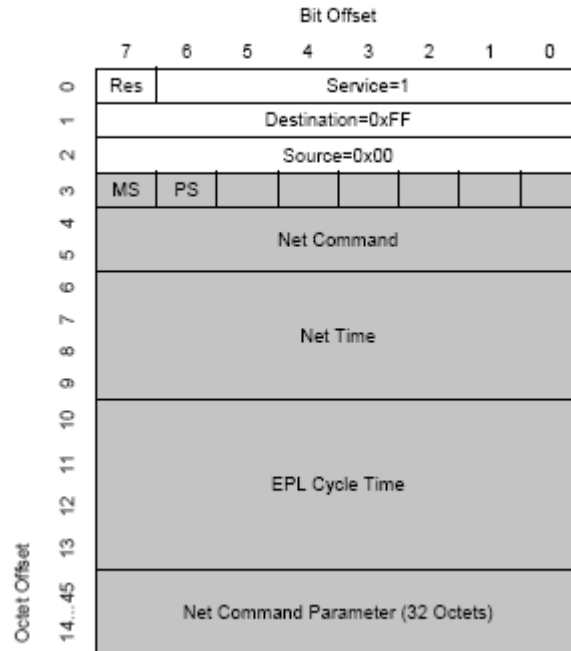

# POSITAL

## FRABA

### ETHERNET POWERLINK USER MANUAL

#### 5.2.1 Powerlink message Poll Request

Data (out data) which is sent from the Managing node (MN) to the Controlled node (CN). Independent if data has to be send out, the PReq mes-

sage is needed to get input data from the controlled node. This message is used to allow the CN a time slot for transmission within an

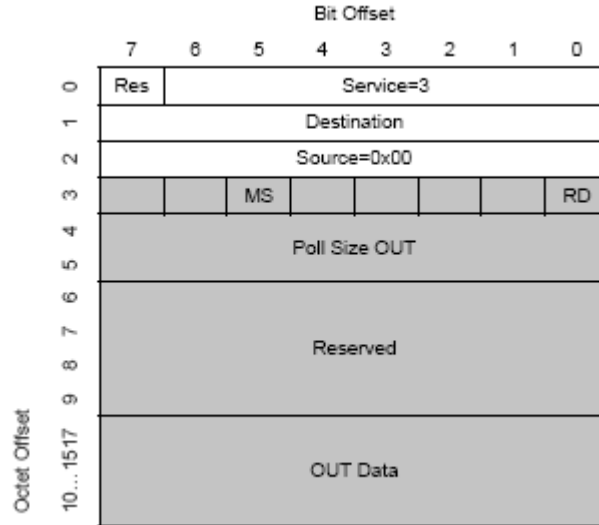

#### 5.2.2 Powerlink message Poll Response

transferred data from a CN to a MN. If the sent data is valid, which is indicated by a set RD flag, the encoder position value is given in the IN DATA field. Minimum size for IN Data is 36 octets according to standard Ethernet framing. Poll size is the size of input data in octets. ER flag: Fatal

error in CN with breakdown of service. MS is used, when multiplexed time slot mode is in operation. WA is a warning flag and the CN is still in operation. EX indicates an exception, that unread entries exist.

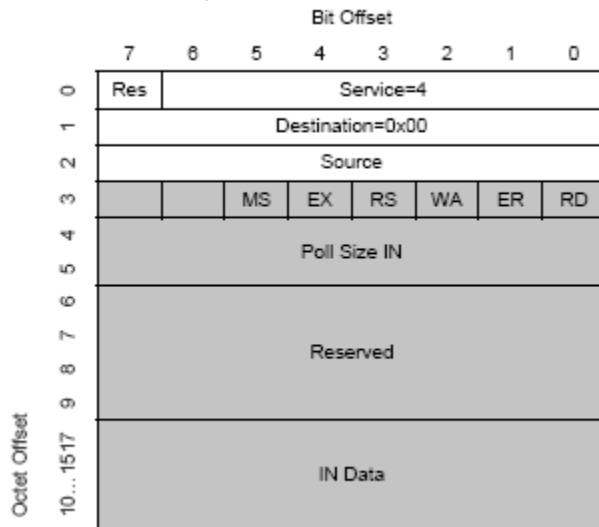

### ETHERNET POWERLINK USER MANUAL

#### 5.2.2 Powerlink message End of Cycle

The End of Cycle message is sent as broadcast information to all CN in the EPL network. With this message the CN are allowed to take over their out data. Additionally the end of isochronous

cycle is indicated. The MN is not sending this frame if an error occurred. Frame size is 64 octets in total with overhead.

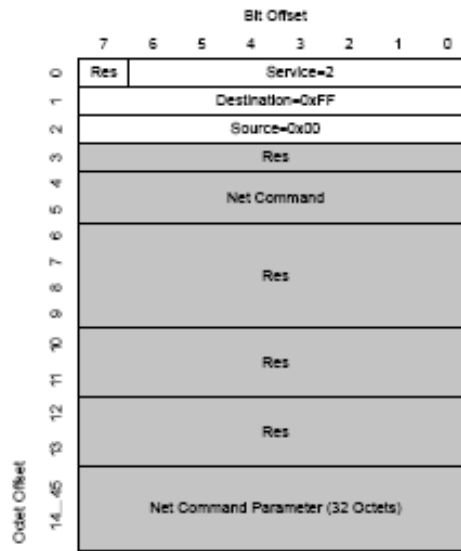

# POSITAL

## FRABA

### ETHERNET POWERLINK USER MANUAL

#### 5.2.2 Powerlink message Ident Channel

This message is only MN internal and can not be accessed by an application. With this message

the MN can identify, how the CN is configured and additional information.

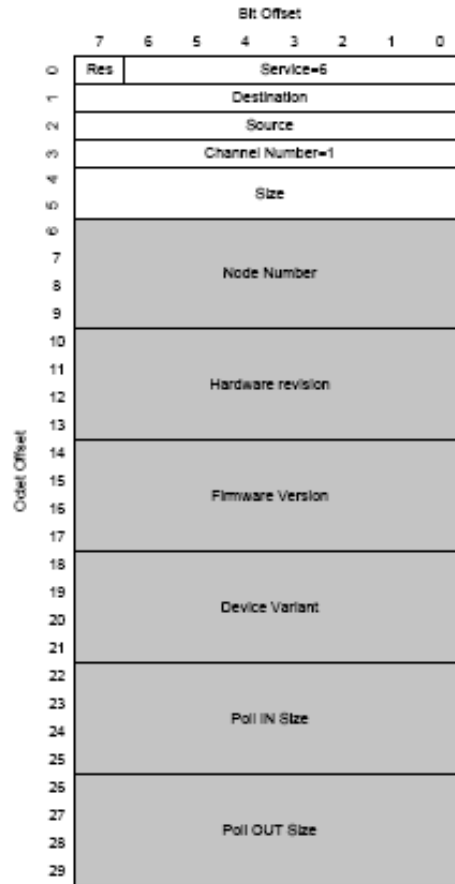

Field	Description
Node number	Number of the node
Hardware revision	CN hardware revision if available, otherwise 0xFFFFFFFF
Firmware version	Firmware version of node. Higher number = newer version.
Firmware variant	To identify firmware targets. Every device has a unique variant number.
Poll IN Size	Number of isochronous net data octets CN'MN (Poll Response frame).
Poll OUT Size	Number of isochronous net data octets MN'CN (Poll Request frame).

#### Encoder settings

Hardware revision: 1  
Firmware revision: 1

Device variant: 150 (dez)  
Poll In size : 8  
Poll out size: 0

### ETHERNET POWERLINK USER MANUAL

## 6. Powerlink protocol Version 2

The Powerlink protocol version 2 is a standard communication protocol and offers for manufacturer and customer maximum of independence, because it is an open protocol and not a manufacturer specific solution. The organization Ethernet POWERLINK Standardization Group can be contacted for any general information and assistance. Organization web site address: [www.ethernet-powerlink.org](http://www.ethernet-powerlink.org).

Our standard Powerlink encoder is capable to support both Powerlink protocol versions: 1 and 2. The customer hasn't got to do a device configuration for a specific protol, because the encoder has an auto-detection. What must be taken into account? It is not allowed to change the protocol during runtime. During power up the network must be in a defined state regarding used protocol, so that the encoder can detect the protocol version telegrams.

### 6.1 Powerlink cycle

The Powerlink protocol offers an isochronous communication. A deterministic transmission is a requirement out of high performance applications. The deterministic network cycle is achieved with a time slot principle, which is Controlled by the managing node. With the SoC telegram (Start of Cyclic) the EPL cycle is initiated. Afterwards the MN (managing node) is sending a poll request to each node,

whereby the CN (controlled node) is sending immediately a response. This frame is called isochronous phase and covers real time data. With the telegram SoA (Start of Asynchronous) an asynchronous phase is started and closed by an AsyncSend telegram. Our Powerlink encoder i.e. tranmits the web applet data within this time frame.

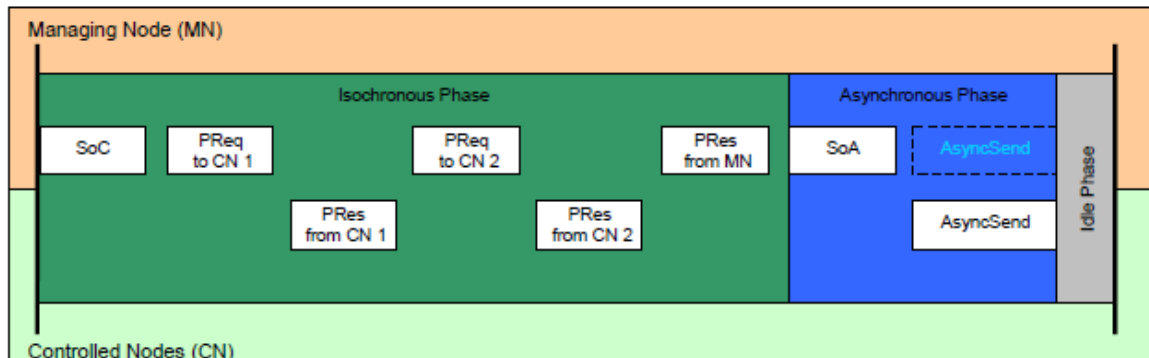

### ETHERNET POWERLINK USER MANUAL

#### 6.2. Encoder Profile

The CANopen Device profiles have been overtaken for the Powerlink protocol to minimize integration effort for the customer. This means for encoders, that device parameters are corresponding to the profile DS406. In the following table the supported parameters are listed:

In this manual we refer to the encoder device profile DS406 V3.2

Object	Description	Data type	Access type
6000h	Operating Parameters	Unsigned 16	r / w
6001h	Measuring units per revolution	Unsigned 32	r / w
6002h	Total measuring range in measuring units	Unsigned 32	r / w
6003h	Preset value	Unsigned 32	r / w
6004h	Position Value	Unsigned 32	r / w
6500h	Operating status	Unsigned 16	r
6501h	Single-turn resolution	Unsigned 32	r
6502h	Number of distinguishable revolutions	Unsigned 32	r
6504h	Supported alarms	Unsigned 16	r
6506h	Supported warnings	Unsigned 16	r

#### Object 6000h: Operating parameters

This object shall indicate the functions for code sequence, commissioning diagnostic control and scaling function control.

Subindex	Description	Data Type	Default Value	Access	
0h	Operating Parameter	Unsigned 16	0h	rw	

Code sequence: The code sequence defines, whether increasing or decreasing position values are output, in case the encoder shaft rotates clockwise or counter clockwise as seen from the point of view of the shaft.

Scaling function control: With the scaling function the encoder numerical value is converted in software to change the physical resolution of the encoder. The measuring units per revolution (object 6001h) and total measuring range in measuring units (object 6002h) are the scaling parameters. The scaling function bit is set in the operating parameters. If the scaling function bit is set to zero, the scaling function is disabled.

### ETHERNET POWERLINK USER MANUAL

Bit structure for the operating parameters

Bit	15	14	13	12	11	10	9	8	7	6	5	4	3	2	1	0
Use	MS	MS	MS	MS	R	R	R	R	R	R	R	R	MD	SFC	CD	CS

Table Description:

MS: Manufacturer Specific Function (not available)

R: Reserved for future use

MD: Measuring direction (not available)

SFC: Scaling function (0 = disable, 1 = enable)

CD: Commissioning diagnostic control (not available)

CS: Code sequence (0 = CW, 1 = CCW)

#### Object 6001h: Measuring units per revolution

This object shall indicate the number of distinguishable steps per revolution.

Subindex	Description	Data Type	Default Value	Access	
0h	Measuring units per revolution	Unsigned 32	see type sign	rw	

#### Object 6002h: Total measuring range in measuring units

This object shall indicate the number of distinguishable steps over the total measuring range.

Subindex	Description	Data Type	Default Value	Access	
0h	Total measuring steps	Unsigned 32	see type sign	rw	

#### Object 6003h: Preset value

This object indicates the preset value for the output position value

Subindex	Description	Data Type	Default Value	Access	
0h	Preset Value	Unsigned 32	0h	rw	

#### Object 6004h: Position value

This object contains the process value of the encoder.

Subindex	Description	Data Type	Default Value	Access	
0h	Process Value	Unsigned 32	-	romap	

#### Object 6500h: Operating status

This object shall provide the operating status of the encoder. It gives information on encoder internal programmed parameters.

Subindex	Description	Data Type	Default Value	Access	
0h	Operating status	Unsigned 16	-	ro	

The operating status object corresponds to the value of the object 6000h.

### ETHERNET POWERLINK USER MANUAL

#### Object 6501h: Single-turn resolution

The object contains the physical measuring steps per revolution of the absolute rotary encoder.

A value written in object 6001h must be lower than defined in 6501.

Subindex	Description	Data Type	Default Value	Access	
0h	Single Turn Resolution	Unsigned 32	see type sign	ro	

#### Object 6502h: Number of distinguishable revolutions

This object contains number of revolutions of the absolute rotary encoder.

A value written in object 6002h must be lower than defined as the multiplication of object 6501h and 6502h.

Object 6002h  $\leq$  6501h \* 6502h.

Subindex	Description	Data Type	Default Value	Access	
0h	Number of Revolutions	Unsigned 16	see type sign	ro	

#### Object 6504h: Supported alarms

The object shall provide the supported alarms of the device. No alarm is supported.

Subindex	Description	Data Type	Default Value	Access	
0h	Supported Alarms	Unsigned 16	0h	Ro	

#### Object 6506h: Supported warnings

The object provides the supported warnings of the device. No warning is supported.

Subindex	Description	Data Type	Default Value	Access	
0h	Supported Warnings	Unsigned 16	0h	ro	

### ETHERNET POWERLINK USER MANUAL

#### 6.3. Web applet

By using the web server functionality an easy way of configuration is offered independent of any communication protocol knowledge. The described objects in section 6.2. for parametrization are also available in the web applet.

For an access just a web browser like INTERNET EXPLORER or Mozilla Firefox is needed. Furthermore the Java Virtual Machine must be activated. In the following screen shots the IP-address 10.10.10.10 is used. When the DIP switches in the connection cap are set in the position ON this address is valid, otherwise any

configured one. In the DIP switch position off the pre-defined factory setting 192.168.100.110 is set for Powerlink devices.

The start site is displayed with a menu which offers under MAIN CONTROLLER SITE a parameter set for device configuration like resolution and code sequence.

In EMAIL and NETWORK CONFIGURATION a desired IP-address can be assigned. If the first 3 values are kept the Powerlink definition is valid and the last number for device node address can be modified (1-240).

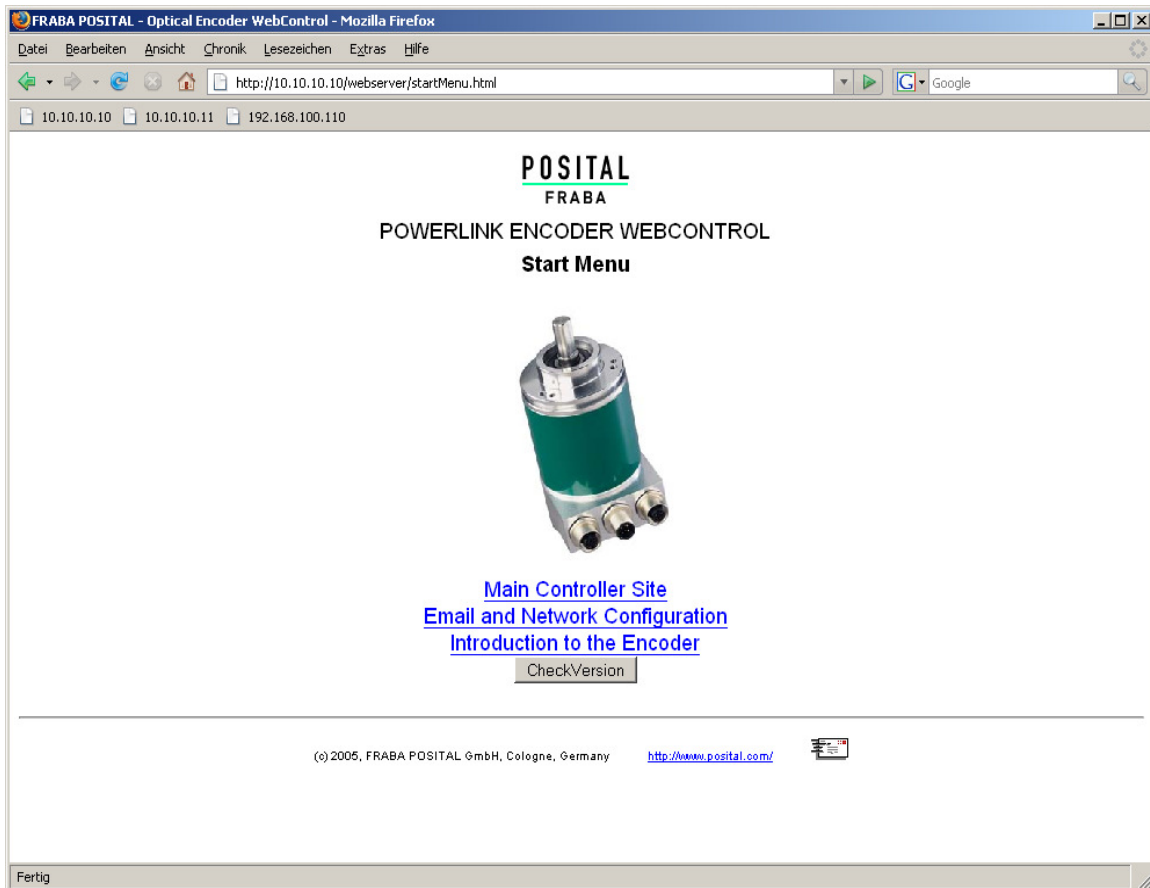

### ETHERNET POWERLINK USER MANUAL

#### Main Controller Site

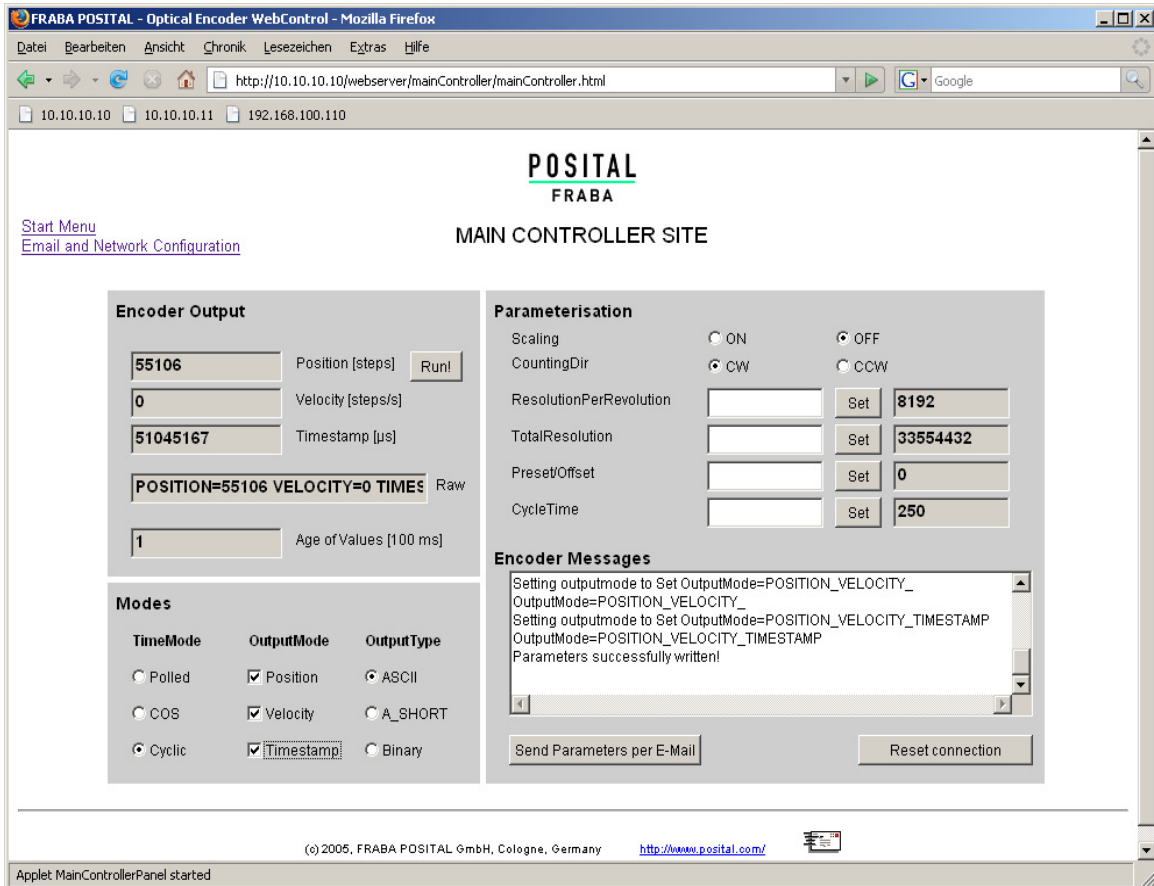

In the right section named “Parameterisation” the parameters for device configuration can be set. As best sequence of setting parameters the order should be overtaken as given in the window. When the preset value is entered in the left side you will see on the right side in the grey colored section an encoder internal offset value displayed just for information purposes. Entered values are transmitted and stored in the encoder when the set button is activated.

The output field “encoder messages” informs about error messages caused by wrong

configuration and telegrams sent from the web applet to the encoder and reverse direction.

“Encoder output” displays the actual encoder output values depending on the configured mode in the frame below named “Modes”. When the polled mode is active, each updated position value must be requested by pressing the RUN! Button.

In the COS (change of state) or Cyclic mode a transmission is generated automatically by the encoder.

# POSITAL

## FRABA

### ETHERNET POWERLINK USER MANUAL

#### E-mail and Network Configuration

The screenshot shows a web browser window titled "FRABA POSITAL - Optical Encoder WebControl - Mozilla Firefox". The address bar shows the URL "http://10.10.10.10/webserver/networkConfig/networkConfig.html". The browser tabs show "10.10.10.10", "10.10.10.11", and "192.168.100.110". The main content area displays the "POSITAL FRABA" logo and the title "E-MAIL AND NETWORK CONFIGURATION". On the left, there are links for "Start Menu" and "Main Controller Site". The configuration area is divided into two sections: "Network - Configuration" and "E-Mail - Configuration".

Network - Configuration	
Encoder IP Address	<input type="text" value="192.168.100.110"/> <input type="button" value="Set"/>
Encoder Netmask	<input type="text" value="255.255.255.0"/> <input type="button" value="Set"/>
Gateway IP Address	<input type="text" value="192.168.100.254"/> <input type="button" value="Set"/>

E-Mail - Configuration	
SMTP-Server IP	<input type="text" value="217.69.67.146"/> <input type="button" value="Set"/>
Mail Sender	<input type="text" value="encoder@posital.de"/> <input type="button" value="Set"/>
Recipient Address	<input type="text" value="info@posital.de"/> <input type="button" value="Set"/>

Applet NetworkConfigPanel started

The input field "Encoder IP address" is used for programming a desired IP-Address, which is active, when the DIP switches in the connection cap are set to position off.

For Powerlink the IP-address is pre-defined: 192.168.100 is the net-ID and the last number the Host-ID. For controlled node an address range of 1-240 is allowed.

### ETHERNET POWERLINK USER MANUAL

## 7 Glossary

Term	Explanation
10 Base T	Transmission line with 10 Mbit data transmission rate
100 Base T	Transmission line with 100 Mbit data transmission rate
ASCII	<b>A</b> merican <b>S</b> tandard <b>C</b> ode for <b>I</b> nformation <b>I</b> nterchange ASCII describes as code the correlation from digital integers to a normal font described character.
Batch file	Script program for MS-DOS
Baudrate	Transmission rate; it display the transmission bits per second
Binary	Numeric system with value 0 or 1.
Browser	Software program to display HTML-Sides on different operating systems (Linux, Unix, Windows, ...)
CAT5	Terminations for transmission rates up to 100 Mbit.
CRC	The <b>c</b> yclic redundancy check is a method from the information technology to control a checksum for data, to reduce errors by the transmission.
EMC	<b>E</b> lectromagnetic compatibility, there are rules to verifying devices.
Ethernet	Ethernet is a computer network technology based on frames.
Fast Ethernet	Transmission technology with 100 Mbit transmission rate.
FCS-Bytes	The <b>F</b> rame <b>C</b> heck <b>S</b> equenz-Bytes are a 32 Bit CRC-Checksum.
Flash	Internal memory, saved data will be available after power down.
HTML	The <b>H</b> ypertext <b>M</b> arkup <b>L</b> anguage is a document format used in the World Wide Web to be displayed by a browser
HTTP	The <b>H</b> ypertext <b>T</b> ransfer <b>P</b> rotocol is a stateless transmission protocol for data transmission.
Hub	The hub connects different network segments e.g. in an Ethernet network.
IP-Adresse	IP-address allow a logic addressing from computer in a network.
IP-Protokoll	The <b>I</b> nternet <b>P</b> rotocol is widespread in computer networks. It is the implementation of the internet layer of the TCP/IP-model
Mbit	Transmission rate or baud rate, million bits per second
OCD	Acronym: <b>O</b> PTOCODE, name of an encoder series manufactured by FRABA POSITAL.
OSI-Modell	The <b>O</b> pen <b>S</b> ystem <b>I</b> nterconnection reference model is a open layer model for the organisation of a communication.
PPP-Packet	The <b>P</b> oint-to- <b>P</b> oint <b>P</b> rotocol will be need for a connection establishment. It enables the transmission between different network protocols.
SMTP	<b>S</b> imple <b>M</b> ail <b>T</b> ransfer <b>P</b> rotocol managed the transmission of e-mails.
Switch	A switch is an electronic device to connect computers e.g. network segments in a local network. Unlike a hub, a switch uses stacks to avoid network collisions.

## ETHERNET POWERLINK USER MANUAL

TCP	The <b>T</b> ransmission <b>C</b> ontrol <b>P</b> rotocol is a connection orientated transmission protocol, in a network.
TCP-Client	MS-DOS program available from FRABA to communicate with the encoder.
UDP	<b>U</b> ser <b>D</b> atagram <b>P</b> rotocol is utilized to send data that does not need to be transferred in a reliable way.

### 8 History

#### Version document 1.00

Initial version of this document.

#### Version document 2.00

With encoder version 01 the pin out of the Ethernet connector is changed. This is documented in the manual revision V2.00.