

# POSITAL

## FRABA

### ABSOLUTE ROTARY ENCODER PROFINET IO



#### Main Features

- Compact and heavy duty industrial model
- Interface: Profinet IO
- Housing: 58 mm Ø
- Full shaft: 6 or 10 mm Ø / hollow shaft 15 mm Ø
- Resolution: max. 30 Bit = 1,073,741,824 steps over 16,384 revolutions
- Code: Binary

#### Programmable Parameters

- Resolution
- Total resolution
- Preset value
- Direction of rotation (complement)
- Velocity
- IP-Address

#### Mechanical Structure

- Flange and housing, Aluminum and Brass respectively
- Stainless steel shaft
- Precision ball bearings with sealing rings
- Code disc made of durable and unbreakable plastic
- Robust electrical connection with M12-connector

#### Electrical Features

- Integrated IRT-compatible switch
- Status indication with six LEDs
- Temperature insensitive  
IR-Opto-receiver-ASIC
- Polarity inversion protection
- Over-voltage-peak protection

### ABSOLUTE ROTARY ENCODER PROFINET IO

#### Technical Data

##### Electrical Data

Supply voltage	10 - 30 V DC (absolute limits)
Power consumption	max. 4 Watt
EMC	Emitted interference: EN 61000-6-4
	Noise immunity: EN 61326-1
Bus connection	Profinet IO
Transmission rate	100 MBit
Accuracy of division	$\pm \frac{1}{2}$ LSB (up to 12 Bit), $\pm 2$ LSB (up to 16 Bit)
Step frequency LSB	max. 800kHz (valid code)
Cycle time	$\leq 1$ ms (IRT), $\leq 10$ ms (RT)
Internal cycle time	$\sim 500$ $\mu$ s
Electrical lifetime	$> 10^5$ h
Device addressing	Programmable IP-Address by the master

##### Mechanical Data

Housing	Aluminum, optional stainless steel		
Lifetime	Dependent on shaft version and shaft loading – refer to table		
Max. shaft load	Axial 40 N, radial 110 N		
Inertia of rotor	$\leq 30$ gcm <sup>2</sup>		
Friction torque	$\leq 3$ Ncm (without shaft sealing)		
RPM (continuous operation)	max. 12,000 RPM		
Shock (EN 60068-2-27)	$\leq 30$ g (halfsine, 11 ms)		
Permanent shock (EN 60028-2-29)	$\leq 10$ g (halfsine, 16 ms)		
Vibration (EN 60068-2-6)	$\leq 10$ g (10 Hz ... 1,000 Hz)		
Weight (standard version)	Singleturn: $\approx 500$ g		
	Multiturn: $\approx 700$ g		
<b>Flange</b>	<b>Synchro (S)</b>		<b>Clamp (C)</b>
Shaft diameter	6 mm	10 mm	10 mm
Shaft length	10 mm	20mm	20 mm
hollow shaft depth min. / max.	-	-	-
			<b>Hollow shaft (B)</b>
			15 mm
			-
			15 mm / 30 mm

### ABSOLUTE ROTARY ENCODER PROFINET IO

#### Minimum (mechanical) lifetime

Flange	Lifetime in 10 <sup>8</sup> revolutions with F <sub>a</sub> / F <sub>r</sub>		
	40 N / 60 N	40 N / 80 N	40 N / 110 N
C10 (Clamp flange 10 x 20)	247	104	40
S10 (Synchro flange 10 x 20)	262	110	42
S6 (Synchro flange 6 x 10) without shaft sealing	822	347	133

S6 (Synchro flange 6 x 10) with shaft sealing: max. 20 N axial, 80 N radial

#### Environmental Conditions

Operating temperature	- 40 .. + 85°C
Storage temperature	- 40 .. + 85 °C
Humidity	98 % (without liquid state)
Protection class (EN 60529)	Casing side: IP 67
	Shaft side: IP 64 (optional with shaft sealing: IP67)

### ABSOLUTE ROTARY ENCODER PROFINET IO

#### Technology

PROFINET is an Industrial Ethernet standard merging plant automation with other enterprise IT resources.

It provides comparable functionality to PROFIBUS with techniques used by engineering, IT, and management personnel.

Established IT standards are employed as basis of communication: TCP, UDP, IP. XML is used

as description language for device profiles (GSDML files).

For further information about the function principle or the setup of a PROFINET network please, refer to the manual on [www.posita.com](http://www.posita.com) or <http://www.profibus.com/pn>.

PROFINET offers scalable communication for different applications in industrial automation:

- PROFINET NRT (non real time) is suited for non-time-critical process automation with clock rates of roughly 100 msec.
- PROFINET RT (real time) offers a communication channel with optimized performance (10 msec clock rate) for most factory automation tasks
- PROFINET IRT (isochronous real time) employs special communication hardware to enable clock rates of under 1 msec and a jitter precision of less than 1 µsec. This channel is mainly of use for motion control applications.

After completion of the engineering the installer loads the data for the expansion into the IO controller (PLC) and the IO controller assumes data exchange with the IO device.

An IO device is addressed within PROFINET (and also possibly by external IT components) through its IP address.

Data can be exchanged from the IO controller to the IO device (and vice versa) cyclically (for process data). Apart from this, parameter data can be exchanged acyclically during engineering of the IO device or by the use of PLC programming blocks.

PROFINET IO uses a view of distributed I/O similar to PROFIBUS DP. IO controllers (e.g. PLCs) run an automation program, IO devices (e.g. absolute encoders) are remotely assigned field devices, and IO supervisors (e.g. programming devices) are used for commissioning and diagnostics.

The engineering of PROFINET IO is done similar to PROFIBUS. The field buses (i.e. Ethernet topologies) are assigned to control systems during configuration. The IO device is configured in the actual system based on the contents of its GSDML file.

### ABSOLUTE ROTARY ENCODER PROFINET IO

#### Pinning

##### Connector Ethernet

4 pin female, D-coded

Pin Number	Signal
1	Tx +
2	Rx +
3	Tx -
4	Rx -

##### Connector power supply

4 pin male, A-coded

Pin Number	Signal
1	US (10 - 30 V DC)
2	N.C.
3	GND (0V)
4	N.C.

Sketch on encoder view



#### Diagnostic

LED	Color	Description for LED = on
Active1	Yellow	Incoming and outgoing traffic for port 1
Link1*	Green	Link to another Ethernet component for port 1
Active2	Yellow	Incoming and outgoing traffic for port 2
Link2*	Green	Link to another Ethernet component for port 2
Stat1	Green	Status 1, details in the user manual
Stat2	Red	Status 2, details in the user manual

\* Flashes with 2Hz if engineering identification call is activated and link connection is available

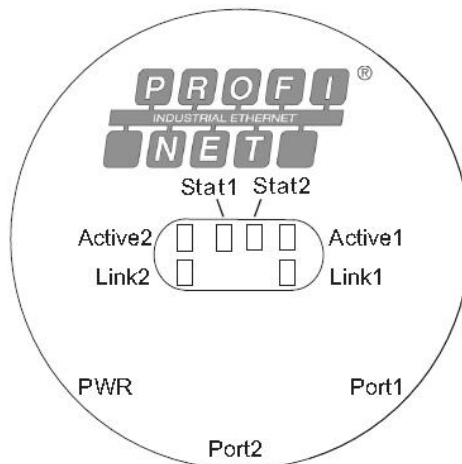

### ABSOLUTE ROTARY ENCODER PROFINET IO

#### Programmable Parameters

The Profinet IO interface supports CLASS 3 and CLASS 4 functionality according to the encoder profile V4 (PNO No. 3.162). Class 4 supports the IRT functionality for isochronous communication for high performance. In addition to these

functions the GSDML-file supports further features. Further more, the following encoder parameters can be programmed directly via the Profinet IO network without any extra device:

Counting Direction	This parameter counting direction defines whether the output code increases or decreases when the shaft rotates clockwise.
Resolution per Revolution	The parameter 'resolution per revolution' is used to program the desired number of steps per revolution. Each value between 1 and the physical resolution per revolution can be programmed.
Total Resolution	This parameter is used to program the desired number of measuring units over the total measuring range. This value may not exceed the total physical resolution of the absolute rotary encoder.
Preset Value	The preset value is the desired position value, which should be reached at a certain physical position of the axis. The position value is set to the desired process value by the parameter preset.
Velocity	The implemented software can additionally deliver the current velocity. This value is transmitted in binary code, in addition to the process value. It is possible to choose between four different units: steps per 10 ms, per 100 ms, per 1000 ms and revolutions per minute.

Details are available in the user manual. These can be downloaded free of charge from our homepage [www.posita.de](http://www.posita.de).

#### Additional features

- Integrated Boot loader for customer firmware upgrades
- Round axis (Endless shaft)
- Engineering identification call
- Neighboring detection
- Different filters for velocity

### ABSOLUTE ROTARY ENCODER PROFINET IO

#### Mechanical Drawings

#### Synchro Flange (S)

available in 2 versions

Synchro flange	d / mm	l / mm
Version S06	6 <sub>f6</sub>	10
Version S10	10 <sub>h8</sub>	20

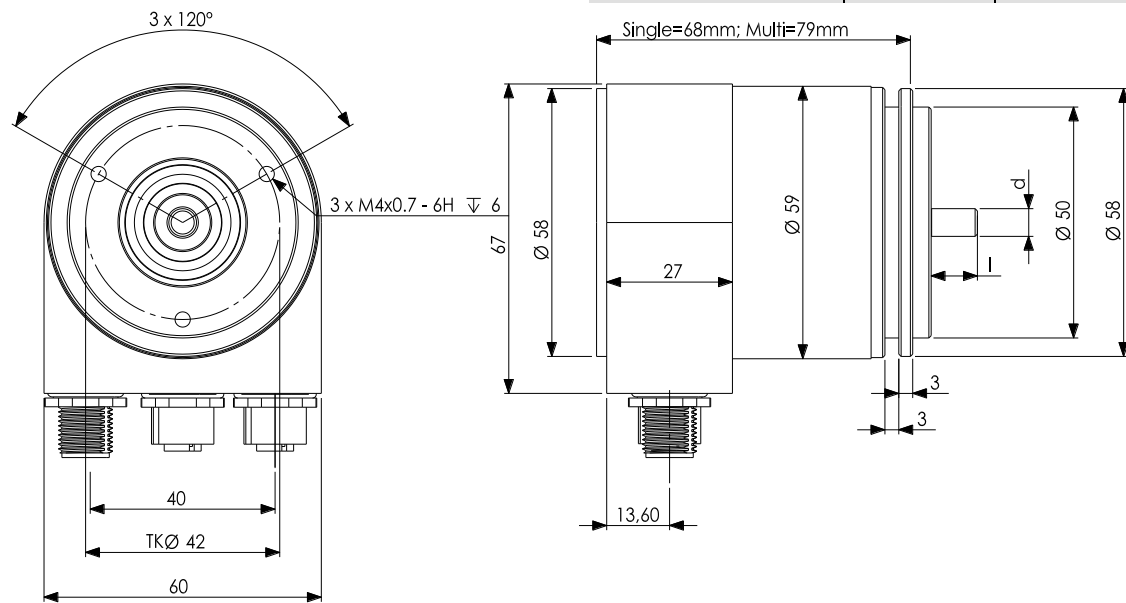

Clamp Flange (F)

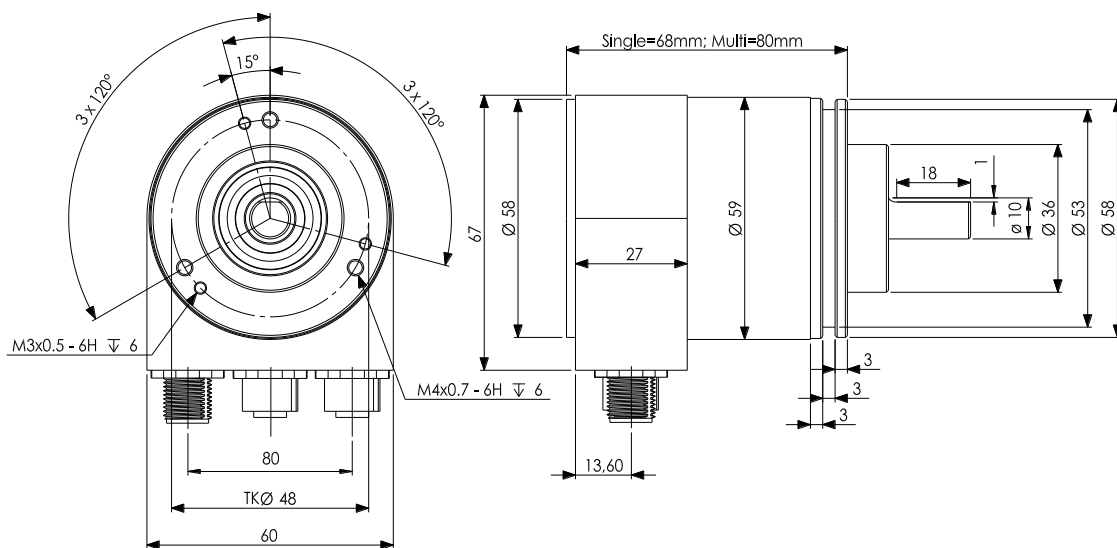

## ABSOLUTE ROTARY ENCODER PROFINET IO

### Hollow shaft (B)

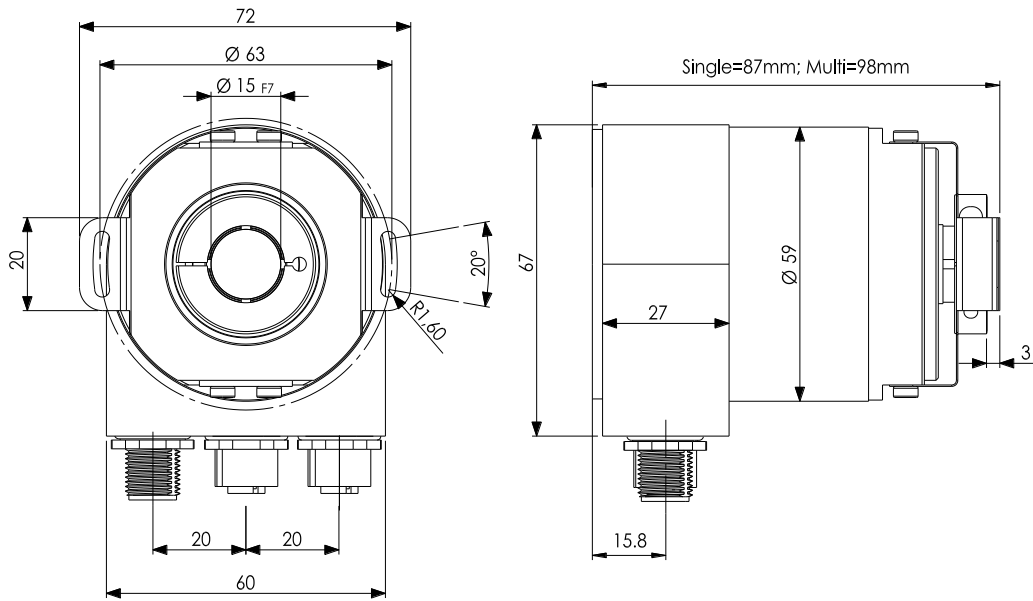

### Mounting instructions

The clamp ring should only be tightened after the shaft of the driving element was inserted into the hollow shaft.

The diameter of the hollow shaft can be reduced to 12 mm, 10 mm or 8 mm by using an adapter (this reducing adapter can be pushed into the hollow shaft).

Maximum radial and axial misalignment of the drive shaft:

	axial	radial
static	± 0.3 mm	± 0.5 mm
dynamic	± 0.1 mm	± 0.2 mm

### ABSOLUTE ROTARY ENCODER PROFINET IO

#### Models/Ordering Description

Description	Type	Key							
Optocode	<b>OCD-</b>	<b>EI</b>	<b>A1</b>	<b>B -</b>	---	---	---	---	- PRM
Interface	Profinet IRT+RT	<b>EI</b>							
Version			<b>A1</b>						
Code	Binary			<b>B</b>					
Revolutions	Singleturn						<b>00</b>		
(Bits)	Multiturn (4,096 revolutions)						<b>12</b>		
	Multiturn (16,384 revolutions)						14		
Steps per revolution	8,192						<b>13</b>		
	65,536						16		
Flange / Shaft diameter	Clamp flange, full shaft:			Ø 10 mm				<b>C10</b>	
	Synchro flange, full shaft:			Ø 6 mm				<b>S06</b>	
				Ø 10 mm				S10	
	Blind hollow shaft, hollow shaft :			Ø 15 mm				<b>B15</b>	
Mechanical options	Without							<b>0</b>	
	Shaft sealing (IP67)							S	
	Customized							C	
Connection	M12 connector								<b>PRM</b>

**Standard = bold**, further models on request

### ABSOLUTE ROTARY ENCODER PROFINET IO

#### Accessories and Documentation

Description		Type
Male cable connector	M12, 4 pin, D-Coded	PAM4
Female cable connector	M12, 5 pin	PAM5
Coupling *	Drilling: Ø 10 mm	GS 10
	Drilling: Ø 6 mm	GS 06
Clamp disc *	Set = 4 pcs.	SP 15
Clamp half-ring *	Set = 2 pcs.	SP H
Reducing adapter **	15 mm to 14 mm	RR14
	15 mm to 12 mm	RR12
	15 mm to 11 mm	RR11
	15 mm to 10 mm	RR10
	15 mm to 8 mm	RR8
User manual *	Installation / configuration manual, German	UME-EI
GSDML file *		

\* These can be downloaded free of charge from our homepage [www.posital.de](http://www.posital.de).

\*\* usable only for hollow shaft

We do not assume responsibility for technical inaccuracies or omissions. Specifications are subject to change without notice.